

DAEWOO

Service Manual

VCR MECHANISM UNIT

(T-MECHA DECK)

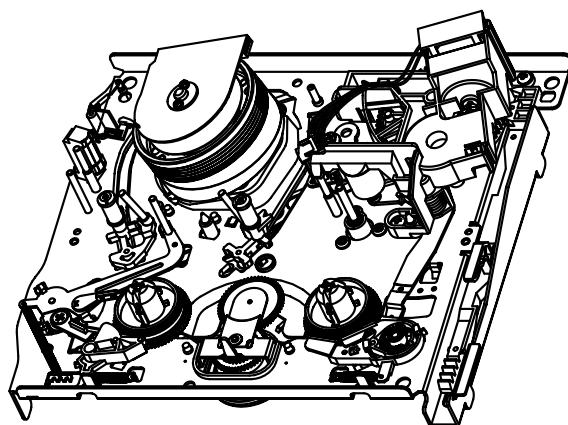

DAEWOO ELECTRONICS CO., LTD.

<http://svc.dwe.co.kr>

Feb. 2000

CONTENTS

1. ASSEMBLY DIAGRAM AND A/S	2
2. WIRE DIAGRAM.....	5
3. PERIODIC MAINTENANCE AND SERVICE SCHEDULE	6
4. SERVICE SCHEDULE FOR THE MAJOR PARTS	7
5. JIGS AND TOOLS.....	8
6. DEASSEMBLY AND REPLACEMENT	10
7. MECHANICAL ADJUSTMENT.....	16
8. ADJUSTMENT OF THE TAPE TRANSPORTING SECTION	19
9. EXPLODED VIEW AND PARTLIST	25

ASSEMBLY DIAGRAM AND A/S

1. Assembly diagram

1-1. DECK Assembly diagram

A. Upper View

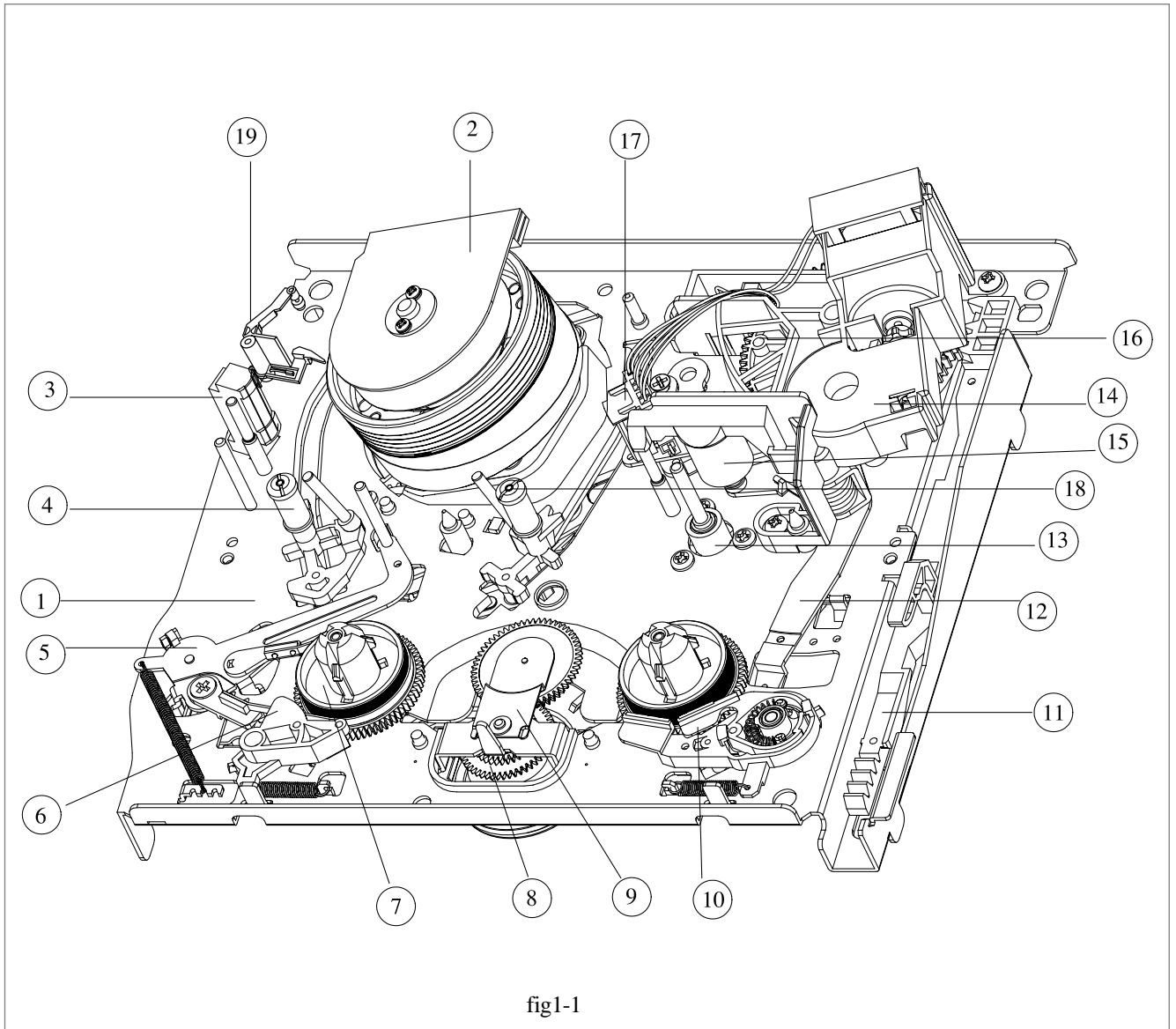

- | | | |
|-------------------------|----------------------------|-----------------------|
| 1 MAINBASE ASS'Y | 9 IDLER PLATE TOTAL ASS'Y | 17 AC HEAD ASS'Y |
| 2 DRUM ASS'Y | 10 T BRAKE ASS'Y | 18 T SLANT POLE ASS'Y |
| 3 FE HEAD | 11 FL RACK | 19 HEAD CLEANER |
| 4 S SLANT POLE ASS'Y | 12 RELAY LEVER | |
| 5 TENSION BAND ASS'Y | 13 CAPSTAN MOTOR | |
| 6 S BRAKE ASS'Y | 14 LC BRKT ASS'Y | |
| 7 S REEL TABLE | 15 PINCH LEVER TOTAL ASS'Y | |
| 8 REEL BRKT TOTAL ASS'Y | 16 CAM GEAR | |

ASSEMBLY DIAGRAM AND A/S (CONTINUED)

B. Lower View

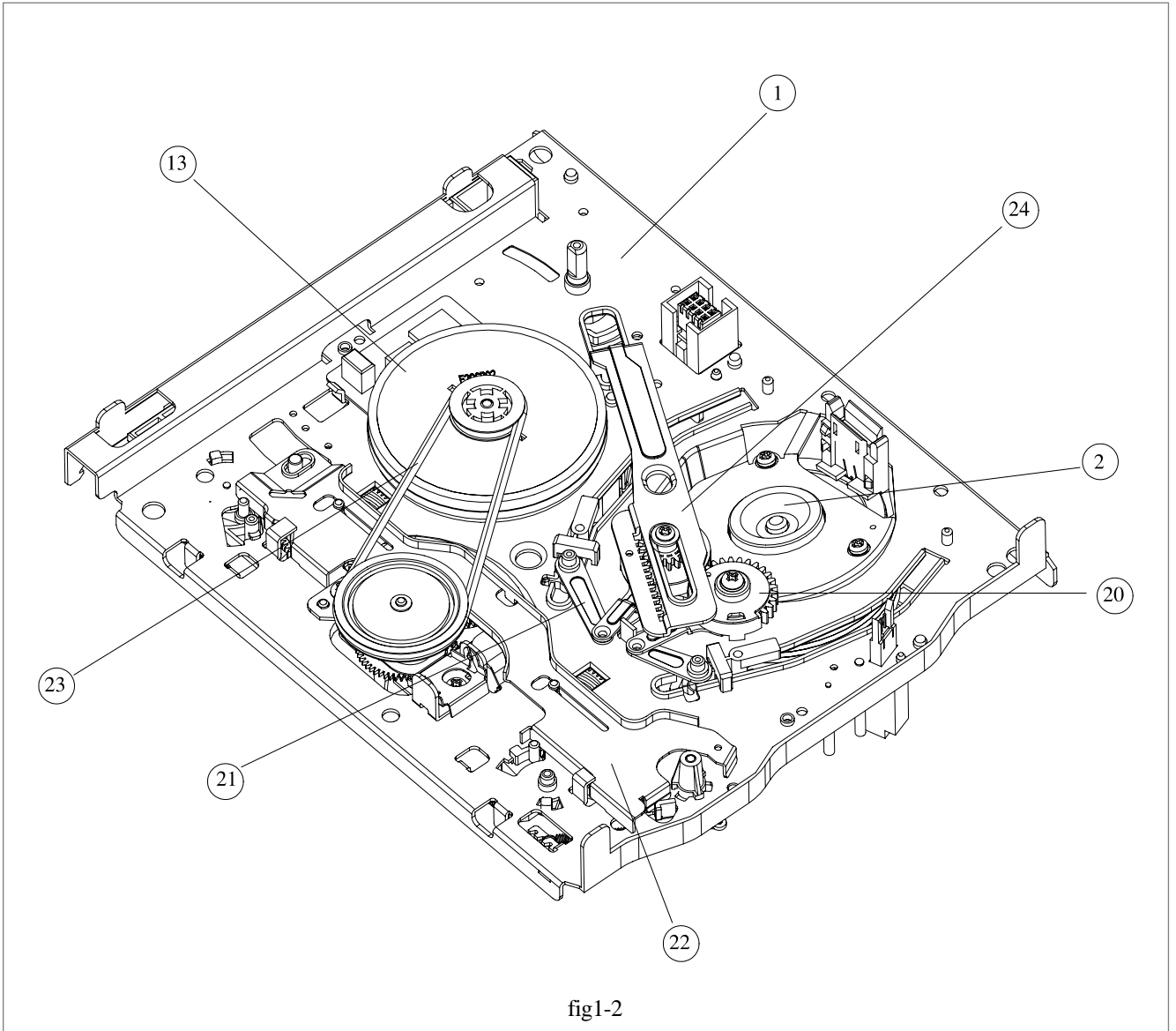

20 L LOADING ASS'Y

21 R LOADING ASS'Y

22 CONNECT PLATE

23 REEL BELT

24 LOADING RACK

ASSEMBLY DIAGRAM AND A/S (CONTINUED)

1-2. FRONT LOADING Assembly diagram

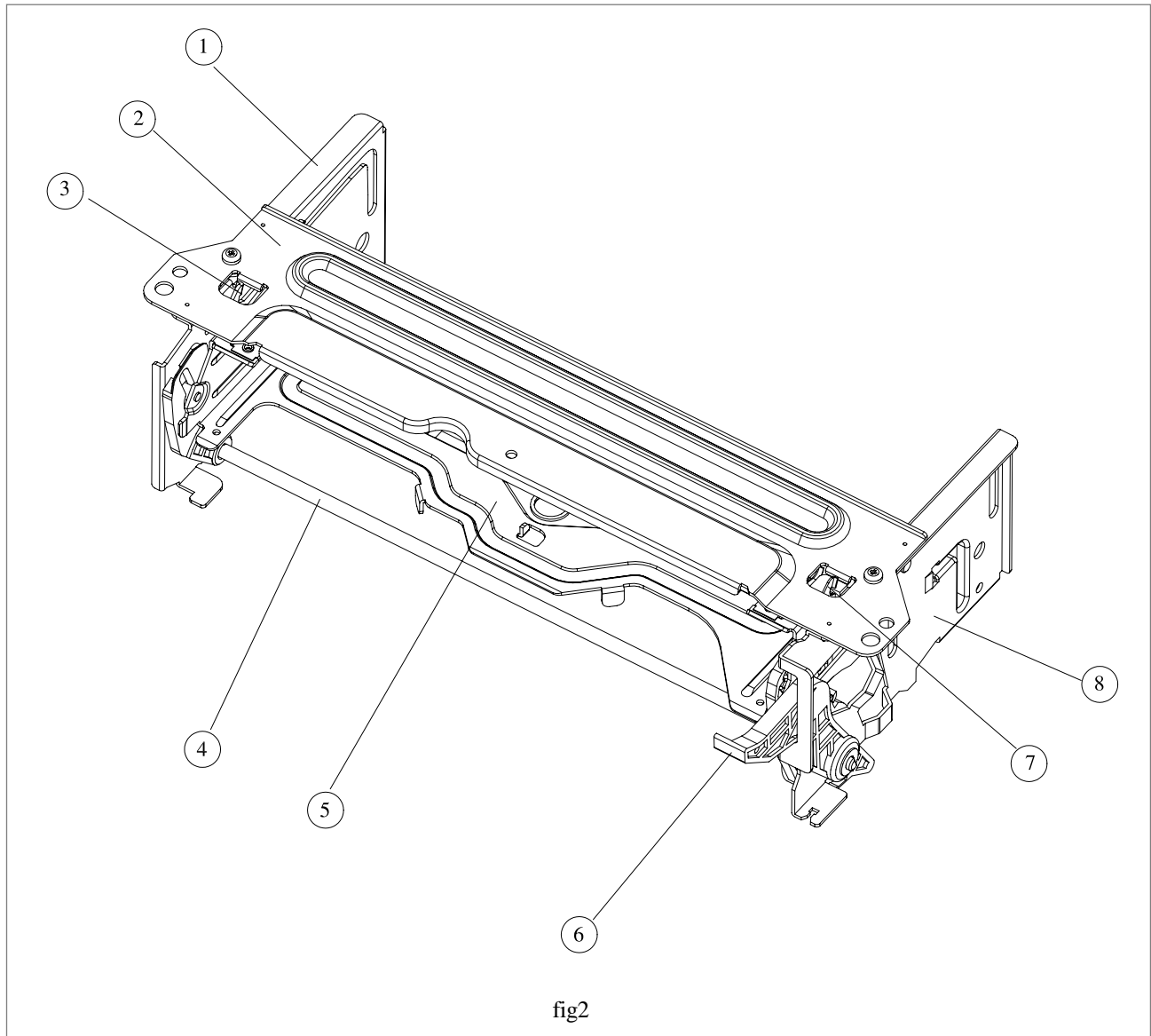

1 FL BRKT L

2 TOP PLATE

3 SAFETY LEVER

4 LOADING LEVER AS4

5 CST HOLDER AS

6 DOOR OPENER

7 SAFETY LEVER R

8 FL BRKT R

WIRE DIAGRAM

1. Wire Diagram

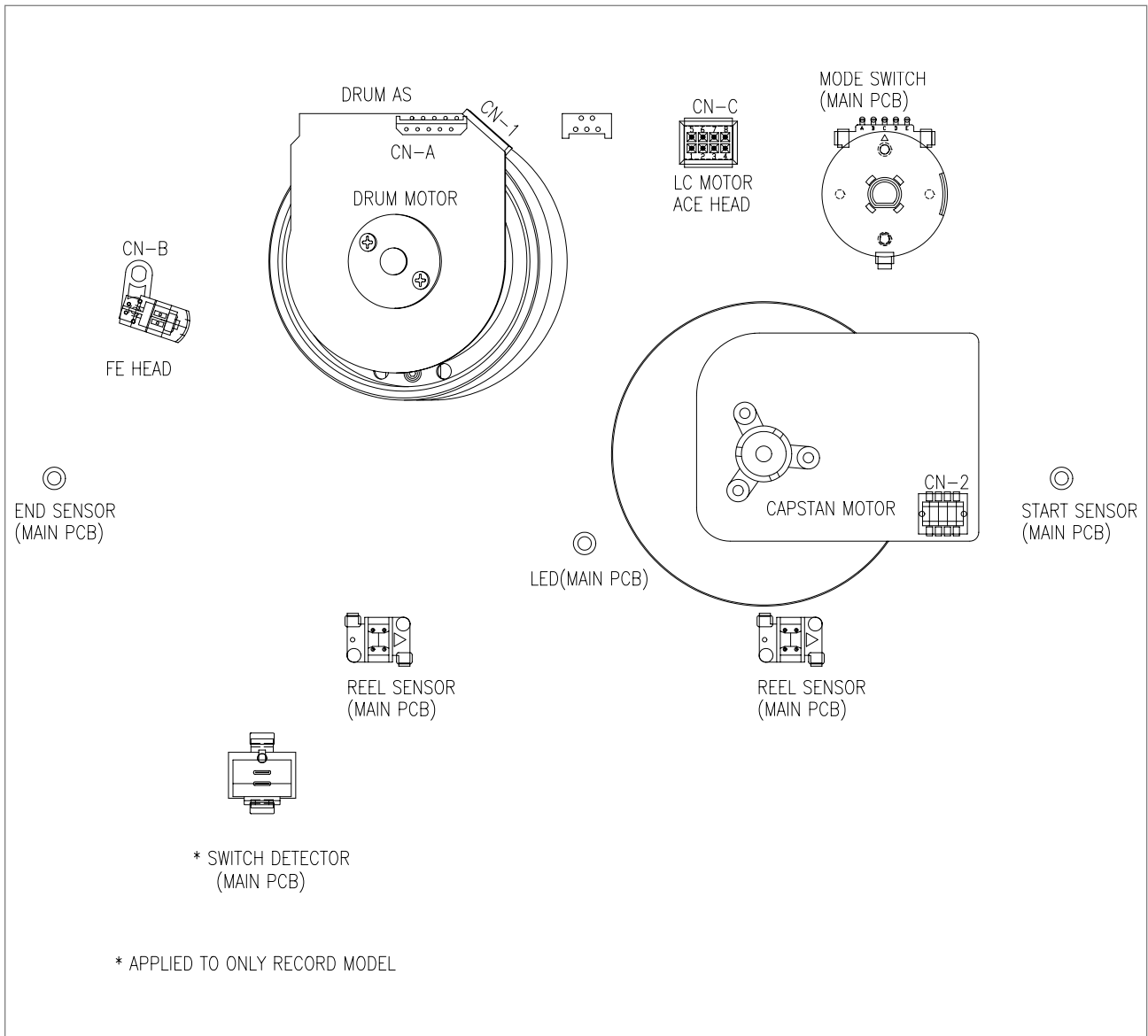

2. Connector Pin Arrangement

		CN-A		CN-B		CN-C		CN-1		CN-2	
4HEAD Hi-Fi		1	AFM-L	1	FE HEAD	1	AE HEAD	1	GND	1	GND
		2	AFM COMM	2	GND	2	CTL(-)	2	D.PWM	2	GND
2HEAD		3	AFM-R			3	GND	3	D.Vcc	3	C.I.LIMIT
		4	SP-L			4	CTL(+)	4	D.FG	4	C.PWM
		5	SP COMM			5	A.HEAD(PB)	5	D.PG	5	Vcc
		6	SP-R			6	LM(+)			6	C.FG
4HEAD MONO		7	GND			7	A.HEAD(REC)			7	C.F/R
		8	EP-R			8	LM(-)			8	EVER 5V
		9	EP COMM								
		10	EP-L								

PERIODIC MAINTENANCE AND SERVICE SCHEDULE

1. PERIODIC MAINTENANCE AND SERVICE SCHEDULE

A. In order to effectively maintain the excellent performance and fully utilize the features of this apparatus, and to lengthen the life of the mechanism and tapes, we strongly urge you to perform periodic maintenance and inspection, as described below.

* After repairing, do the maintenance described below, irrespective of the length of time in use.

B. Cleaning of the Head Drum Ass'y

- Clean the Drum assembly with a cleaning cloth soaked in liquid cleaner (alcohol) by placing lightly against the Drum and slowly revolving the rotating HEAD DRUM Ass'y by hand (Do not rotate the upper Drum by applying electric power to the motor when cleaning).
- Do not move the cleaning cloth in the vertical direction against the heat-tip.

C. Cleaning the tape transporting section.

- Clean the tape transporting parts with a cleaning cloth soaked in alcohol.

D. Cleaning of driving section

- Clean the driving section with a cloth soaked in alcohol.

E. Routine inspection

- Perform maintenance and inspection as separately described depending on the period of time in use.
- Refer to the table of 2-2-3.

2. CLEANING AND LUBRICATION

A. Cleaning of Tape Transporting section and Driving section

a. Cleaning of Tape Transporting section

- The following parts should be cleaned after every 500 hours of use.

- | | |
|-------------------|------------------|
| • TENSION POLE | • S SLANT POLE |
| • AC HEAD/AE HEAD | • S GUIDE POST |
| • VIDEO HEAD/DRUM | • T GUIDE POST |
| • FE HEAD | • T SLANT POLE |
| • CAPSTAN SHAFT | • S GUIDE ROLLER |
| • T GUIDE ROLLER | • PINCH ROLLER |
| • VERTICAL POST | |

- As the above parts contact with the video tape, they tend to collect dust particles. If they are stained with dust or foreign substance it has a bad effect on the picture and may lead to damage of the tape.

- After cleaning with alcohol, allow the parts to dry thoroughly before using a cassette tape.

b. Cleaning of Driving section

- REEL TABLE
- CAPSTAN FLYWHEEL/PULLEY
- REEL PULLEY

B. LUBRICATION

- S REEL POST
- T REEL TABLE POST
- REEL GEAR POST

- After cleaning these parts with alcohol, lubricate these with one or two drops of oil.

SERVICE SCHEDULE FOR THE MAJOR PARTS

SERVICE SCHEDULE FOR THE MAJOR PARTS

The following parts should receive periodic service, according to the recommended intervals.

NAME	PERIODIC SERVICE (TIME)				
	1000	2000	3000	4000	5000
DRUM TOTAL ASS'Y	★	⊙	★	⊙	★
CAPSTAN MOTOR		⊙		⊙	
L/C BRKT TOTAL ASS'Y		⊙		⊙	
REEL BELT		⊙		⊙	
IDLER PLATE TOTAL ASS'Y		⊙		⊙	
REEL TABLE			⊙		
TENSION BAND ASS'Y		⊙	⊙	⊙	
S, T BRAKE ASS'Y		⊙		⊙	
PINCH ROLLER ASS'Y		★	⊙	★	
AC HEAD ASS'Y			⊙		
FE HEAD					⊙
REEL GEAR TOTAL ASS'Y		⊙		⊙	

★ : Check and Replace if necessary. ⊙ : Replace

Note: Even though the unit is not used frequently, cleaning, lubrication and replacement of the belt should be undertaken every 2 years.

JIGS AND TOOLS

1. List of Jigs and Tools

NO	ITEMS	MODEL	FIG. NO	REMARKS
1	ALIGNMENT TAPE	NTSC: SP MONOSCOPE 7KHz SP COLORBAR 1KHz (EP MONOSCOPE) PAL/SCAM: SP MONOSCOPE 6KHz SP COLORBAR 1KHz (LP MONOSCOPE)	①	CHECKING OF THE TAPE TRANSPORTING SYSTEM
2	CLEANING TAPE (DAEWOO)	DHC-602V	②	CHECKING OF THE TAPE TRANSPORTING SYSTEM
3	CASSETTE TAPE (KOKUSAI)	KT-300NV KT-300RV	③	MEASUREMENT OF REEL TORQUE
4	VHS SPINDLE HEIGHT GAUGE	TSH-V4	④	MEASUREMENT OF REEL HEIGHT
5	TENTELO METER (TENTELO)	T2-H7-UM	⑤	MEASUREMENT OF THE BACK TENSION
6	FAN TYPE TENSION METER	BELOW 3KG	⑥	MEASUREMENT OF THE PRESSING FORCE FOR THE PINCH ROLLER
7	DENTAL MIRROR		⑦	CHECKING OF THE TAPE TRANSPORTING SYSTEM
8	+DRIVER		⑧-1	ASSEMBLY, DISASSEMBLY AND ADJUSTMENT
	ADJUSTMENT DRIVER		⑧-2	

JIGS AND TOOLS(CONTINUED)

2. Sketch of Jigs and Tools

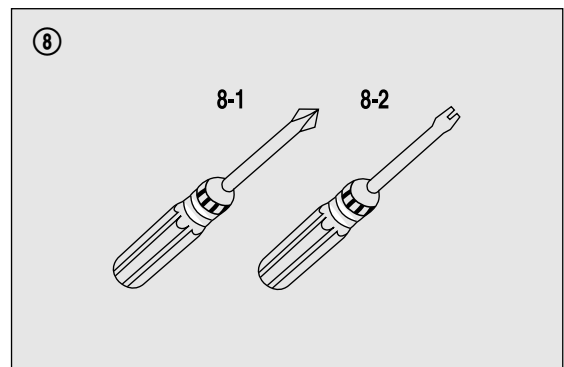
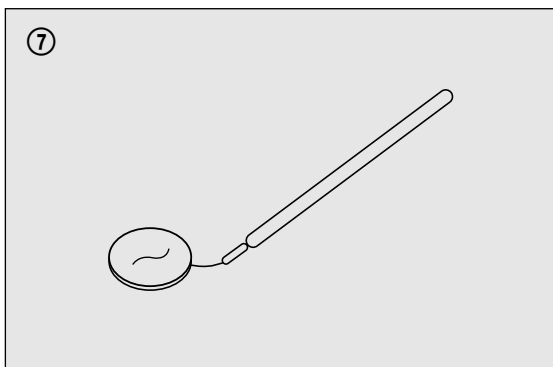
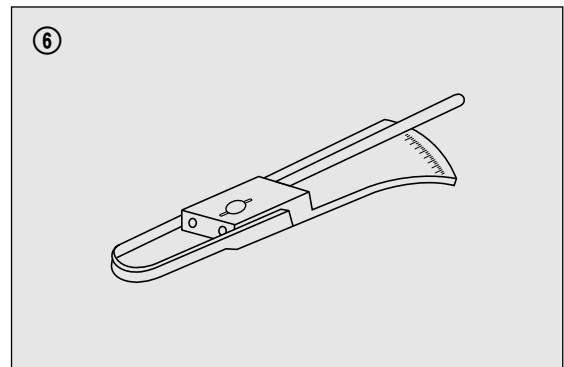
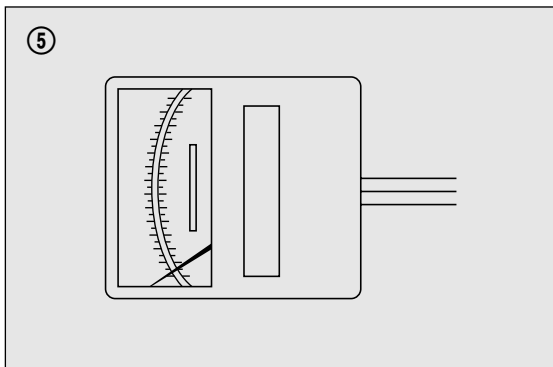
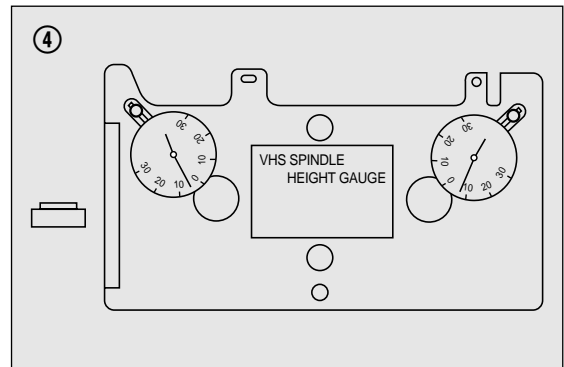
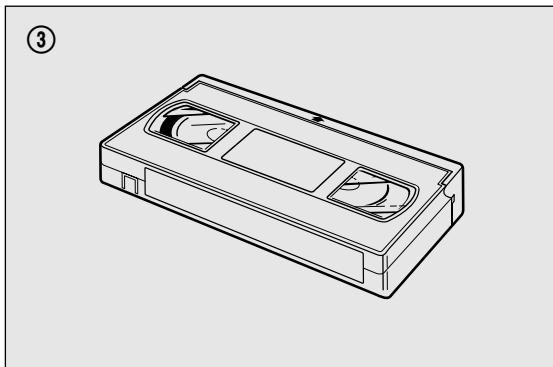

DEASSEMBLY AND REPLACEMENT

1. Removal of the FRONT LOADING Ass'y (Fig. 3.1)

NOTE:

Remove the FRONT LOADING Ass'y in eject mode.

- Unscrew the 2 screw holding the F/L.
- Separate the F/L Ass'y from the MAINBASE settling down point by lifting the rear part of F/L (Screw Hole).

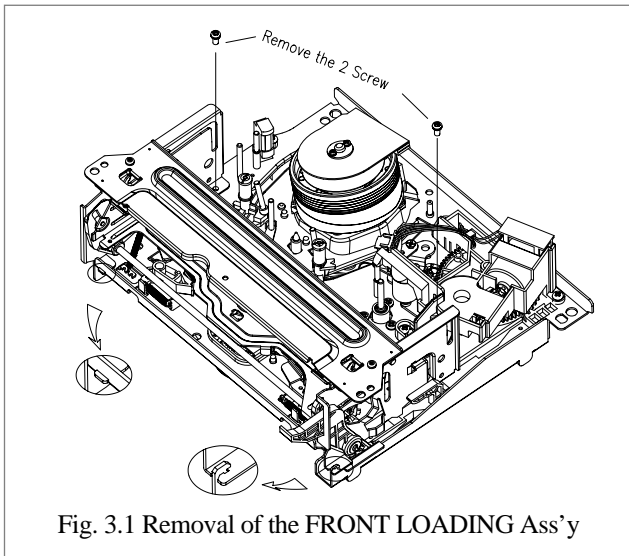

2. Deassembly of FRONT LOADING Ass'y (Fig. 3.2~3.5)

- Remove the 1 washer for holding the door opener and separate F/L Assembly by moving the DOOR OPENER in the direction of arrow.
- Remove the 2 screw holding the TOP PLATE and separate the CASSETTE HOLDER Ass'y by moving the FL BRKT L and FL BRKT R in the direction of arrow. (Fig. 3.2)

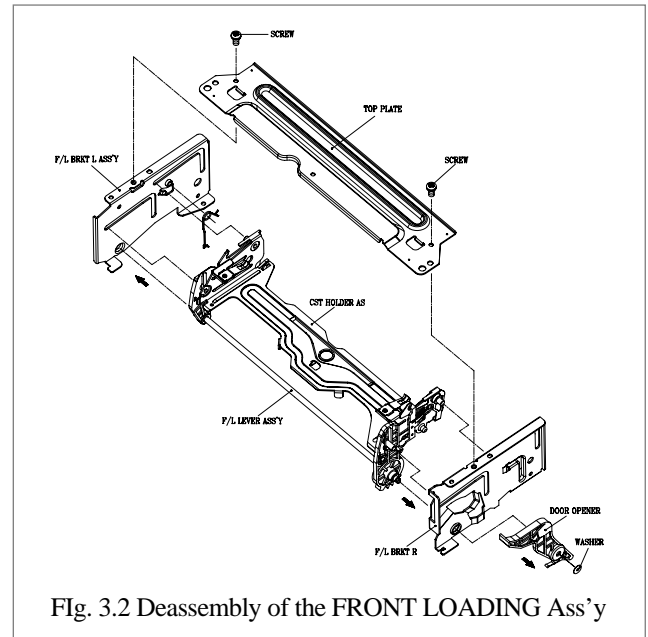

- Separate the FL LIFT SPRING by twisting and dragging from FL BRKT R. (Fig. 3.3)

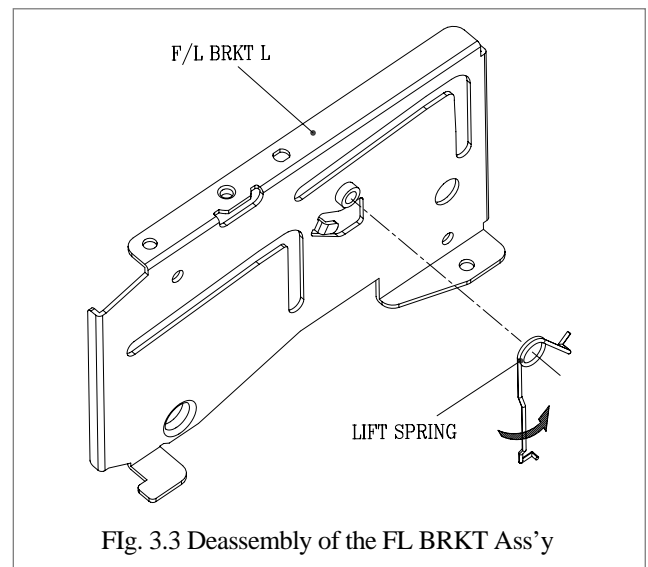

DEASSEMBLY AND REPLACEMENT (CONTINUED)

- d. Separate the LOADING LEVER Ass'y by pressing the connection point from the CASSETTE HOLDER Ass'y. (Fig. 3.4)
- e. Remove the SAFETY SPRING connecting the SAFETY LEVER and CASSTTE HOLDER PLATE. (Fig. 3.4)
- f. Remove the RELEASE SPRING connecting the RELEASE LEVER and SAFETY LEVER. (Fig. 3.4)

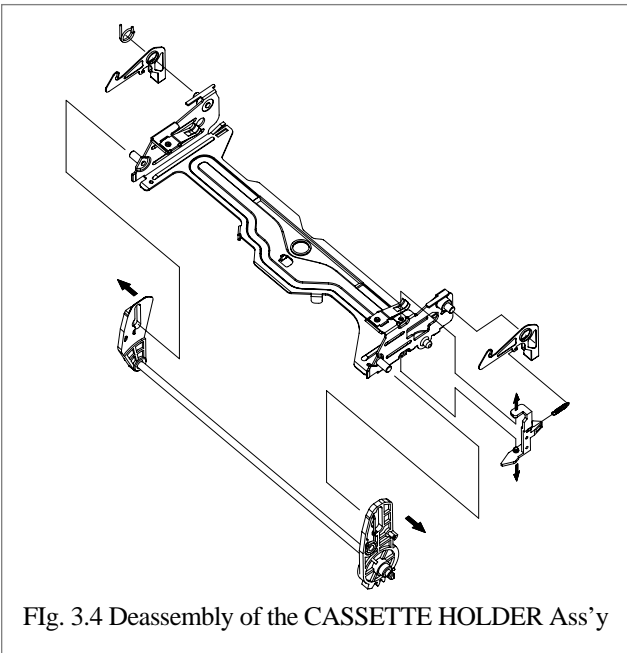

Fig. 3.4 Deassembly of the CASSETTE HOLDER Ass'y

CAUTION:

- Assemble the FRONT LOADING Ass'y in the reverse step of deassembly.
- Confirm that 2 bosses on the left side of the CASSETTE HOLDER Ass'y are inserted in the groove on the left side of the top plate. Insert 2 bosses on the right side of the CASSETTE HOLDER Ass'y into the groove of the F/L BRACKET R. (Fig. 3.5)

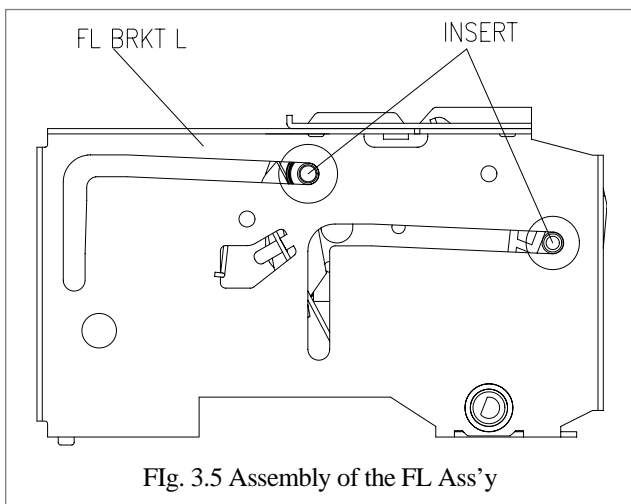

Fig. 3.5 Assembly of the FL Ass'y

3. Deassembly of DRUM Ass'y (Fig. 3.6)

- a. Turn over the DECK MECHANISM and holding the DRUM TOTAL Ass'y ② with hands, remove the 3 screw holding the drum total assembly with mainbase.
- b. Separate the DRUM TOTAL Ass'y from the deck paying attention there is no damage on the surface of VIDEO HEAD and DRUM.
- c. Assembly step is the reverse way of deassembly.

CAUTION:

- After the assembly of the DRUM TOTAL Ass'y, check out if DECK Mechanism operate smoothly and adjustment of tape transmission section is OK.

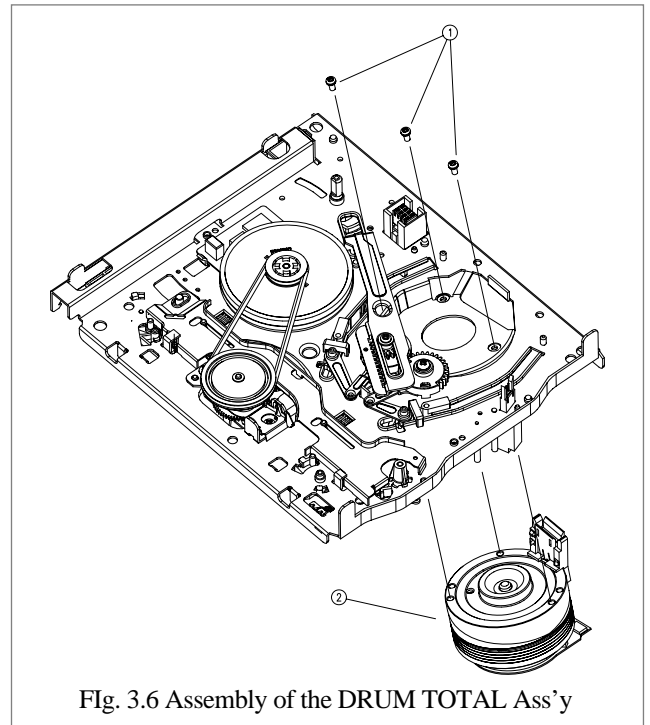

Fig. 3.6 Assembly of the DRUM TOTAL Ass'y

DEASSEMBLY AND REPLACEMENT (CONTINUED)

4. Deassembly of LOADING RACK, LOADING ASS'Y, S/T SLANT POLE ASS'Y (Fig. 3.7, 3.8)

- Turn out the DECK MECHANISM and remove the LOADING RACK ② after unscrewing the SCREW ①.
- Disintegrate the R LOADING AS ③ and L LOADING AS ④.
- Disintegrate the S SLANT POLE AS ⑤ and T SLANT POLE AS ⑥ by moving those part in arrow direction.

CAUTION:

- Take care GUIDE ROLLER of S/T SLANT POLE AS and SLANT POLE not to be stained with grease during assembly.
- Refer to Fig. 3.8 in assembly.

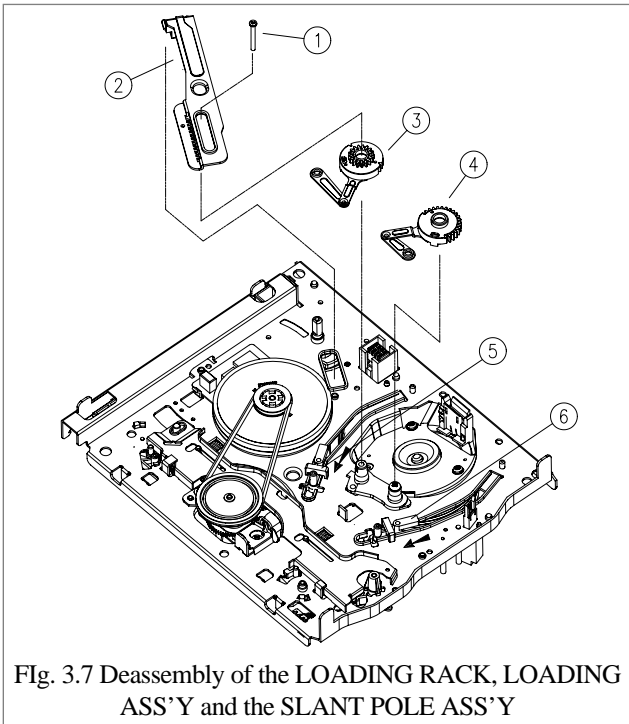

5. Deassembly of the A/C HEAD ASS'Y (Fig. 3.9)

- Remove the CONNECTOR ② from the AC HEAD Ass'y, watch out that there is no damage in the HEAD connecting PIN.
- Separate the AC HEAD Ass'y ① after unscrewing the screw ③.

CAUTION:

- After the assembly, adjust the tape transmission section by referring to the chapter 5.
- After the adjustment of the tape transmission section, paint the 3 adjustment screw with locking paint.

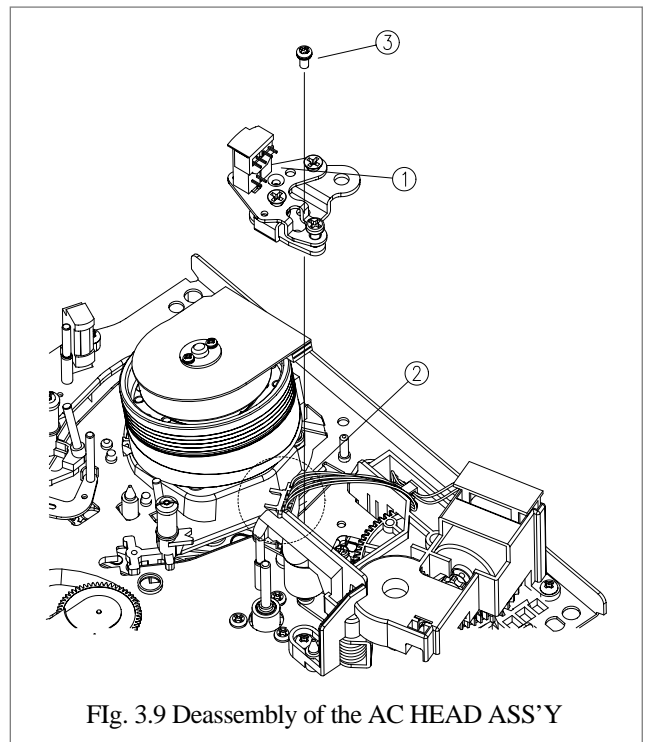

Confirm the Alignment before the assembly of RACK LOADING

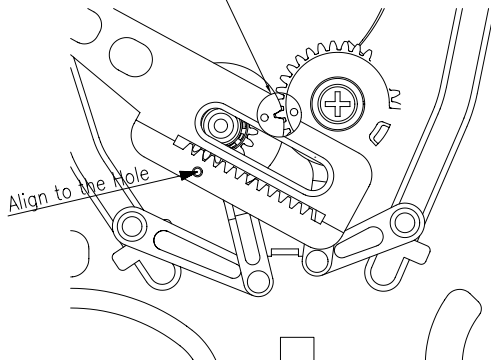

Fig. 3.8 Assembly of the L/R LOADING AS and the LOADING RACK

DEASSEMBLY AND REPLACEMENT (CONTINUED)

6. Deassembly of the LC BRKT ASS'Y, PINCH LEVER TOTAL ASS'Y (Fig. 3.10)

- Separate the LC BRKT Ass'y ② after removing the 3 screw ①.
- Separate the LC BRKT Ass'y ② from the DECK MECHANISM.
- Disintegrate the PINCH LEVER TOTAL Ass'y ③.

CAUTION:

- After the assembly of the PINCH LEVER TOTAL Ass'y, adjust the tape transmission section by referring to the chapter 5.
- There should be no pollution on the surface of PINCH ROLLER ④ with grease or other foreign material.
- Make sure if the end of the PINCH SPRING PINCH "A" is located at the end of trajectory of CAM GEAR "B" in assembly. (Refer to Fig. 4.3)

7. Deassembly of the CAM GEAR, RELAY LEVER, FL RACK (Fig. 3.10)

- Separate the CAM GEAR ⑤ from the MAINBASE.
- Separate the RELAY LEVER ⑥ from the MAINBASE.
- Separate the FL RACK ⑦ from MAINBASE by moving to the arrow direction.

CAUTION:

- When reassembling, refer to Fig. 3.11, Fig. 3.12 and chapter 4.

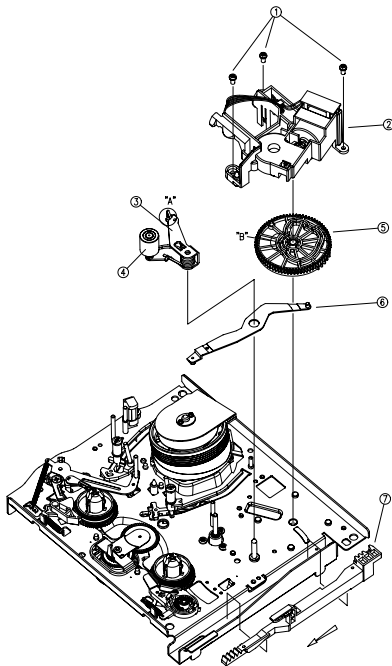

Fig. 3.10 Deassembly of the LC BRACKET ASS'Y from the PINCH LEVER TOTAL ASS'Y

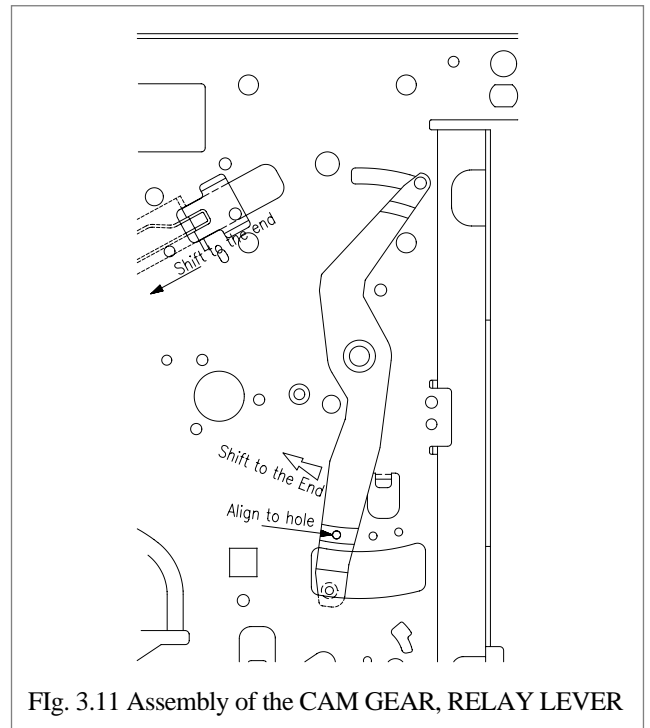

Fig. 3.11 Assembly of the CAM GEAR, RELAY LEVER

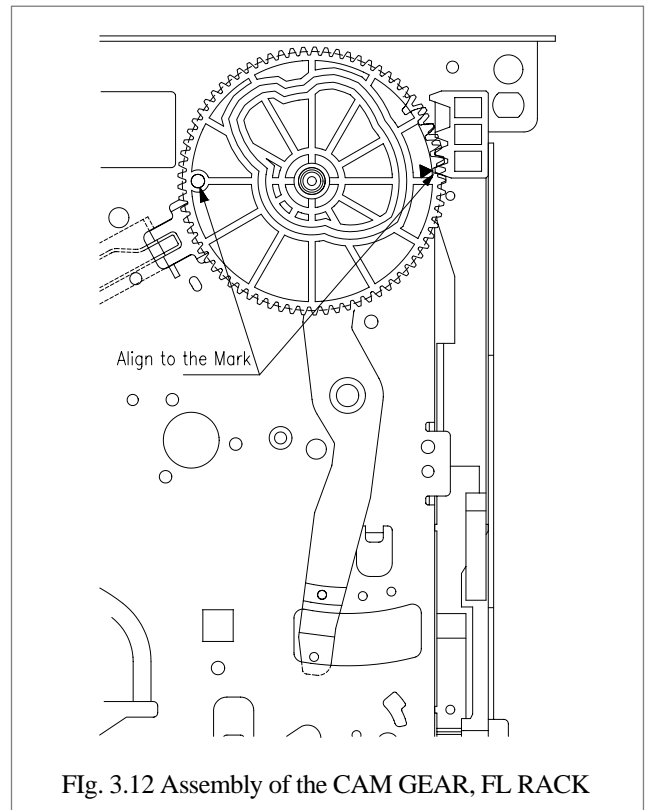

Fig. 3.12 Assembly of the CAM GEAR, FL RACK

DEASSEMBLY AND REPLACEMENT (CONTINUED)

8. Deassembly of the S/T BRAKE ASS'Y (Fig. 3.13)

- Unhook the S BRAKE SPRING ③ from the MAIN-BASE HOOK ①.
- Remove the S BRAKE Ass'y ② from the mainbase.
- Remove the T BRAKE SPRING ⑥ from the MAIN-BASE HOOK ④.
- Remove the T BRAKE Ass'y ⑤.

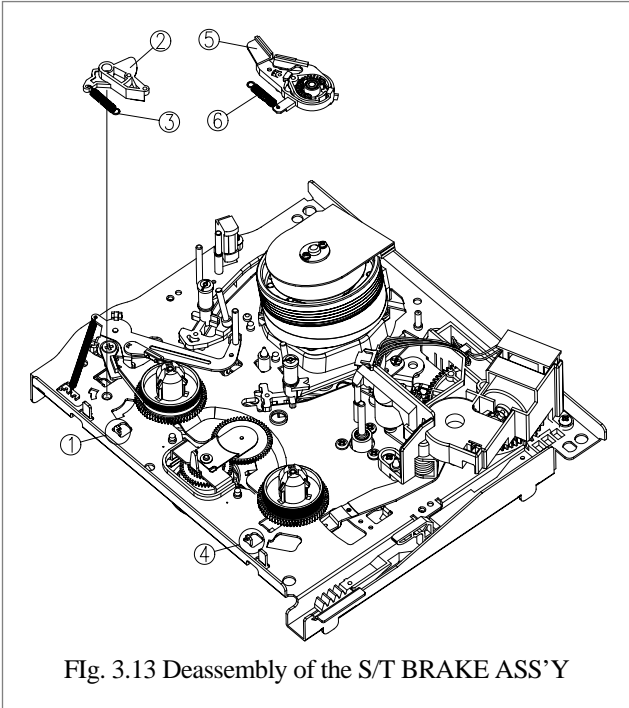

Fig. 3.13 Deassembly of the S/T BRAKE ASS'Y

9. Deassembly of the TENSION BAND ASS'Y (Fig. 3.14)

- Unhook the TENSION SPRING ② from the MAIN-BASE HOOK ①.
- Unhook the MAINBASE HOOK "A" and remove the TENSION BAND Ass'y ③ from the mainbase.

CAUTION:

- After the assembly of TENSION BAND Ass'y on the mainbase, adjust the TENSION POLE location as shown in Fig. 3.15.
- Avoid getting Grease, Oil or Foreign substance on the FELT of the BAND BRAKE.
- Take care not to deform the MAINBASE HOOK "A" when separating the TENSION BAND Ass'y ③.

10. Deassembly of the Capstan Motor (Fig. 3.14)

- Separate the CAPSTAN MOTOR ⑤ after the removal of 3 screw ④ holding the capstan motor.

11. Deassembly of the FE HEAD (Fig. 3.14)

- Unscrew the screw ⑥ and separate the FE HEAD ⑦ from the MAINBASE.

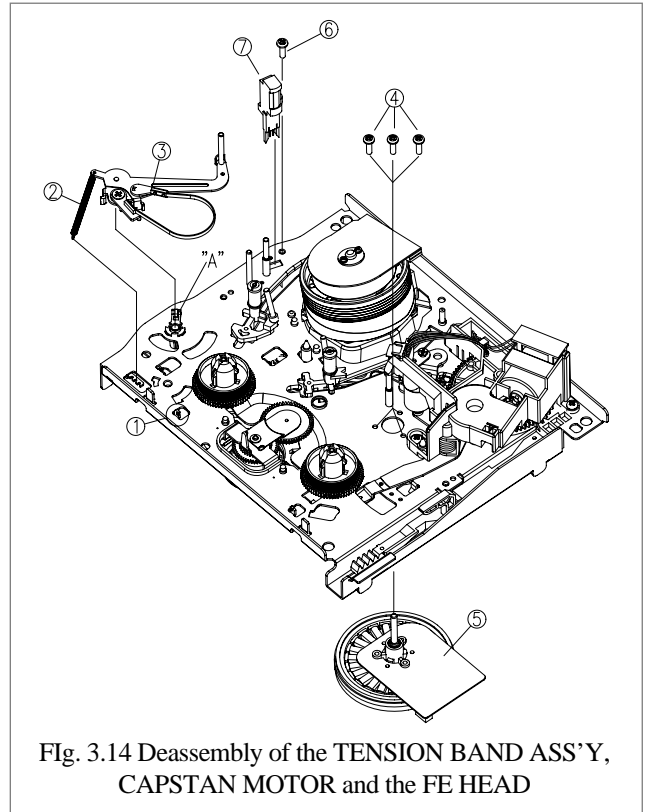

Fig. 3.14 Deassembly of the TENSION BAND ASS'Y, CAPSTAN MOTOR and the FE HEAD

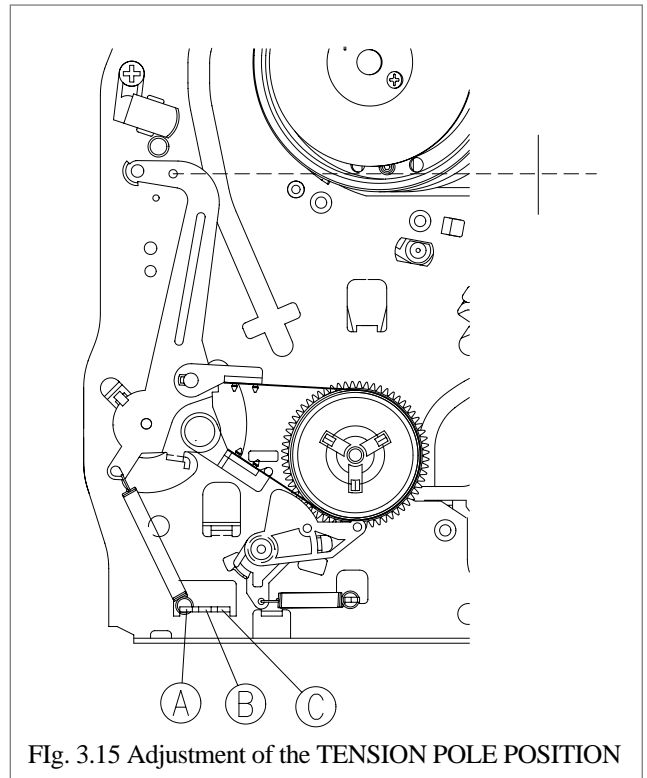

Fig. 3.15 Adjustment of the TENSION POLE POSITION

DEASSEMBLY AND REPLACEMENT (CONTINUED)

12. Deassembly of the REEL TABLE, IDLER PLATE TOTAL ASS'Y (Fig. 3.16)

- a. Remove the POLY WASHER ① and separate the IDLER PLATE TOTAL Ass'y ② from the mainbase.
- b. Remove the REEL TABLE ④ from the REEL TABLE POST ③ of the MAINBASE.

CAUTION:

- Take care not to deform the IDLER PLATE TOTAL Ass'y ② when assembling and deassembling.

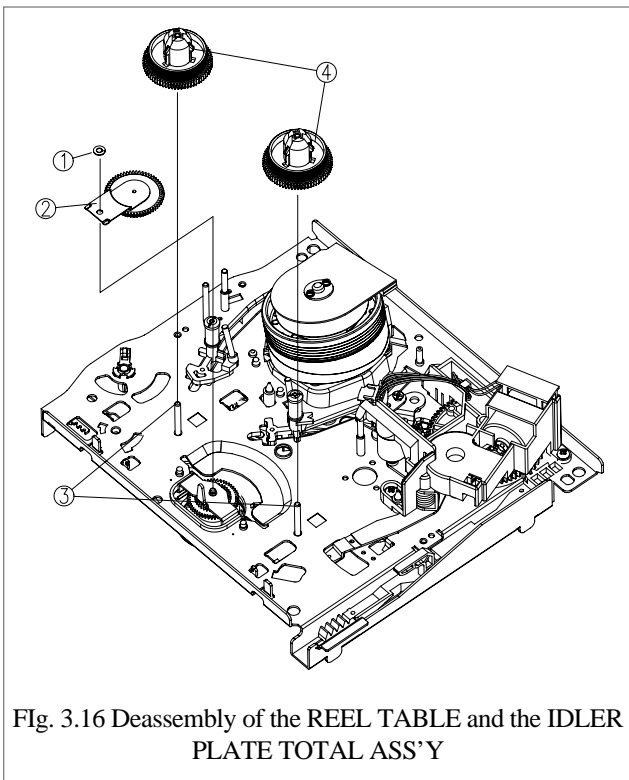

13. Deassembly of the REEL BRKT TOTAL ASS'Y, CONNECT PLATE (Fig. 3.17)

- a. Turn over the DECK MECHANISM and remove the 2 screw ①.
- b. Remove the REEL BRKT TOTAL Ass'y ② from the MAINBASE.
- c. Separate the CONNECT PLATE ③ from the MAINBASE by pushing to the direction of the arrow.

CAUTION:

- In deassembly of the REEL BRKT TOTAL Ass'y, take care REEL BELT and REEL FELT not to be stained with Grease, Oil or Foreign substance.
- Deassembly of the IDLER Ass'y should precede the deassembly of the REEL BRKT TOTAL Ass'y.
- Check the operation of the REEL BRKT TOTAL Ass'y before assembly.
- Check the operation of FF/REW, PLAY, CUE and REVIEW work well and existence of noise during the mode operation.

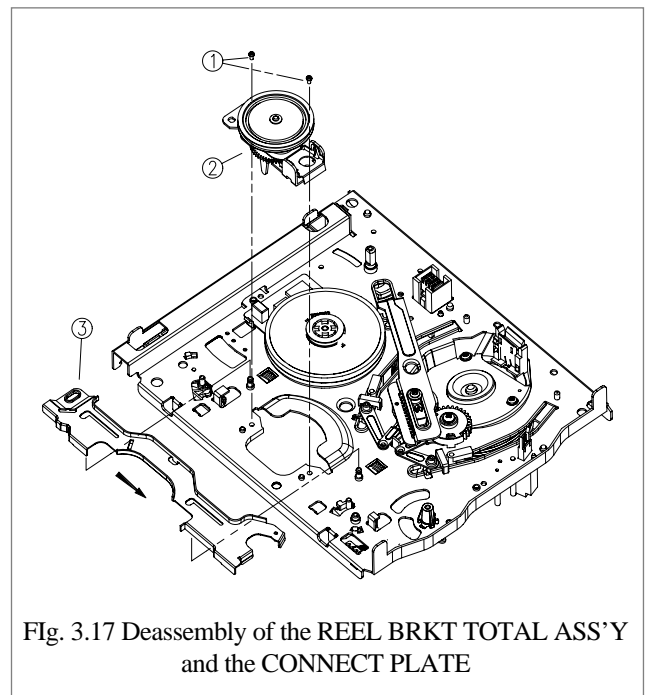

MECHANICAL ADJUSTMENT

1. Mechanical Adjustment (Fig. 4.1~4.4)

In case of deassembly and reassembly for fixing the mechanical problem, check the following check point.

- a. Make sure that the DATUM HOLE of the CAM GEAR is aligned with the DATUM HOLE in the MAINBASE in the EJECT mode as shown in Fig. 4.1.
- b. Make sure that the ending part “A” of the RELAY LEVER assembled on the CONNECT PLATE is aligned with the reference hole “B” of the MAINBASE as shown in Fig. 4.2.
- c. The end point “A” of PINCH SPRINGPING of the LEVER TOTAL Ass’y should be located within the trajectory “B” of the CAM GEAR. (Fig. 4.3)

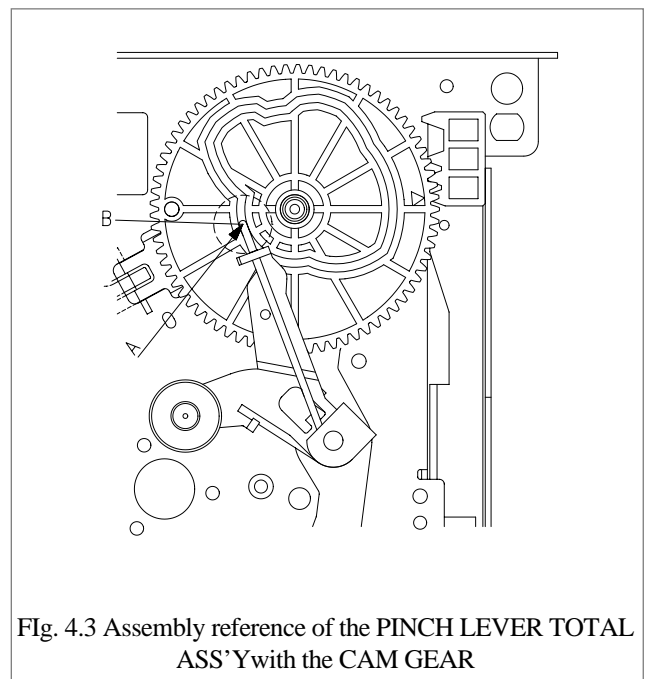
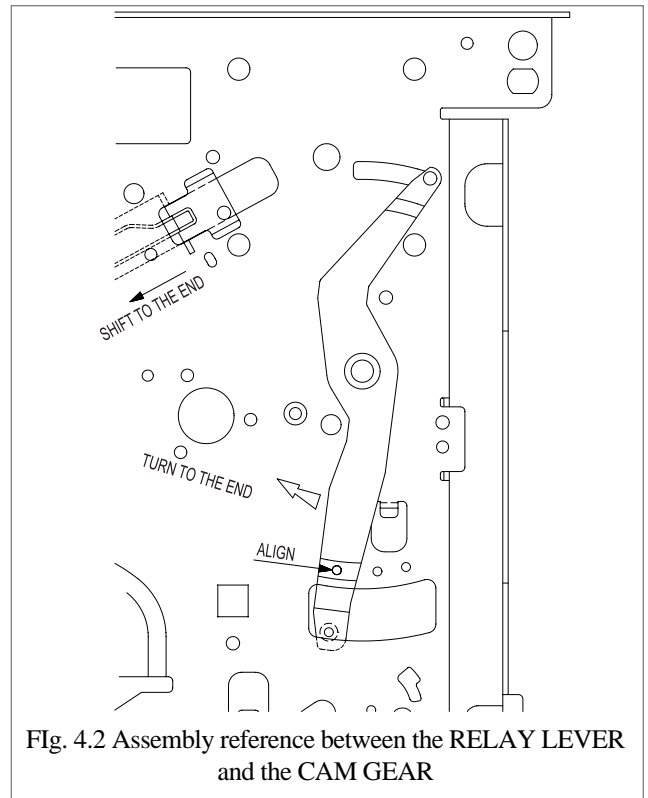
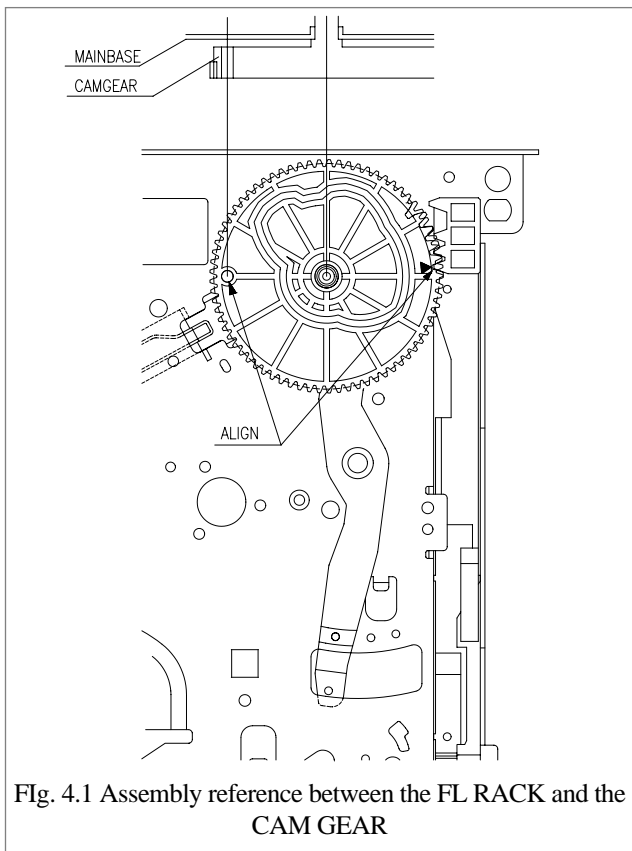

MECHANICAL ADJUSTMENT (CONTINUED)

- d. Make sure that the triangular mark “A” of the L LOADING Ass’y is aligned with the mark “b” of the R LOADING Ass’y. (Fig. 4.4)
- e. Reference hole “C” of the LOADING RACK should be aligned with the reference hole of the R LOADING Ass’y to make the teeth of the LOADING RACK is aligned as shown in Fig. 4.4.

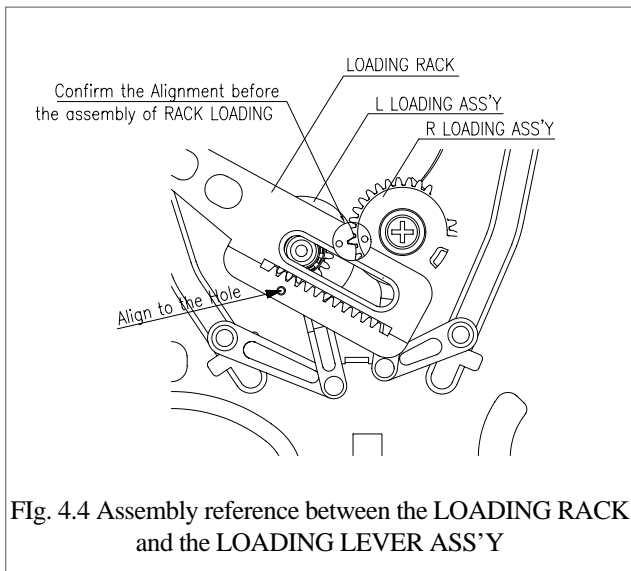

2. Adjustment and measurement of the BACK TENSION (Fig. 4.5, 4.6)

- a. Check that the location of the TENSION POLE is in the right position. If not, adjust that by referring to the “4. Adjustment of the position of the TENSION POLE”.
- b. Playback the T-120 Tape in S-MAX for 20 seconds. (Generally tape transporting section is settled down in 20 seconds)
- c. Measure the BACK TENSION by using the TENTELO METER. (Refer to Fig. 4.5) The result should be within the range of 20g~30g.
- d. If the BACK TENSION is out of the range, change the position of the TENSION SPRING of repeat the process of “4. Adjustment of the position of the TENSION POLE”. (Fig. 4.6)

CAUTION:

- If the measurement result greater than the upper limit, change the hook point of the spring to the “A”.
- Confirm that all of the three probes of TENSION meter are in contact with the tape.
- During measuring, don't touch any other parts of the MECHANISM(i.e, MAINBASE). It is recommended that this measurement be repeated at least three times for an accurate reading.

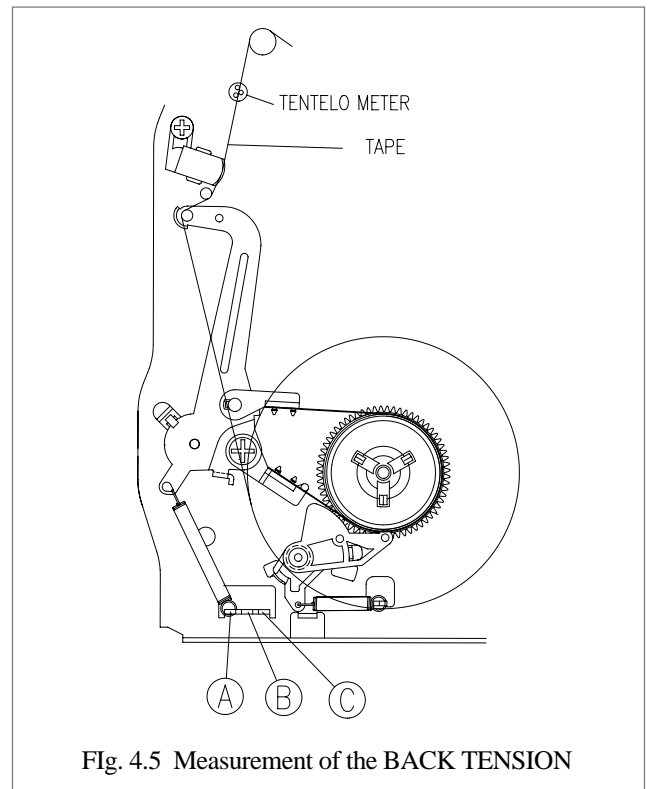

MECHANICAL ADJUSTMENT (CONTINUED)

3. Mechanical Mode (Operate without a cassette tape)

- a. Remove the FRONT LOADING Mechanism from the DECK Mechanism.
- b. Cap the IR LED and pull the FL RACK. This has the same effect with cassette loading to the deck.
- c. If the S/T POLE BASE is loaded, Play mode starts automatically. If you want other function, press the corresponding button.
- d. Turn off the poser when the Mechanism is in the desired position.

4. Adjustment of the position of the TENSION POLE (Fig. 4.6)

- a. Place the Mechanical mode in the play mode. Refer to the above section "3. Mechanical mode".
- b. Confirm that the TENSION LEVER is aligned with the datum hole of the MAINBASE.
- c. If the requirement "b" is not satisfied, turn the BAND BRAKE ADJUST CAP clockwise or counterclockwise until the two datum holes aligns with each other.

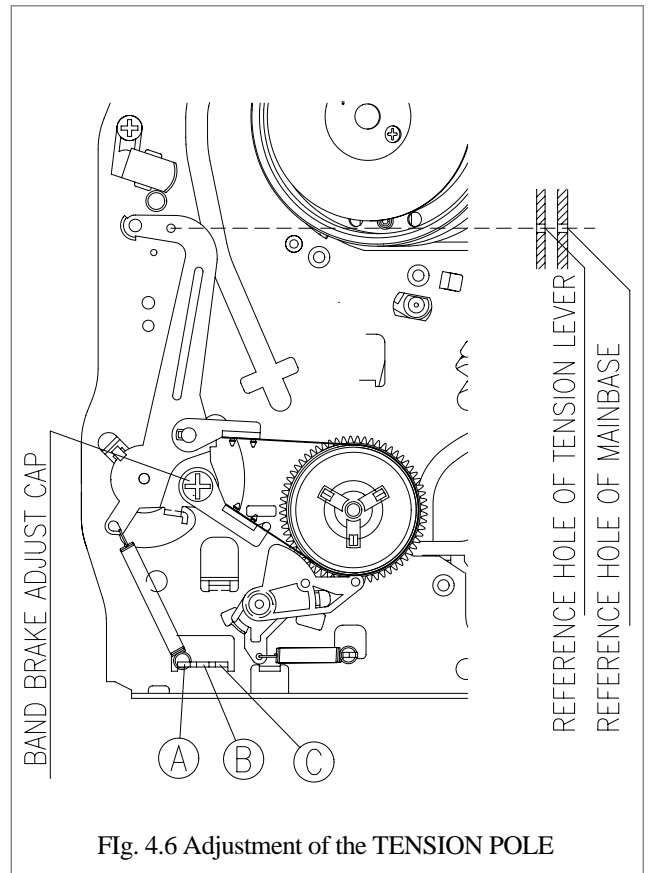
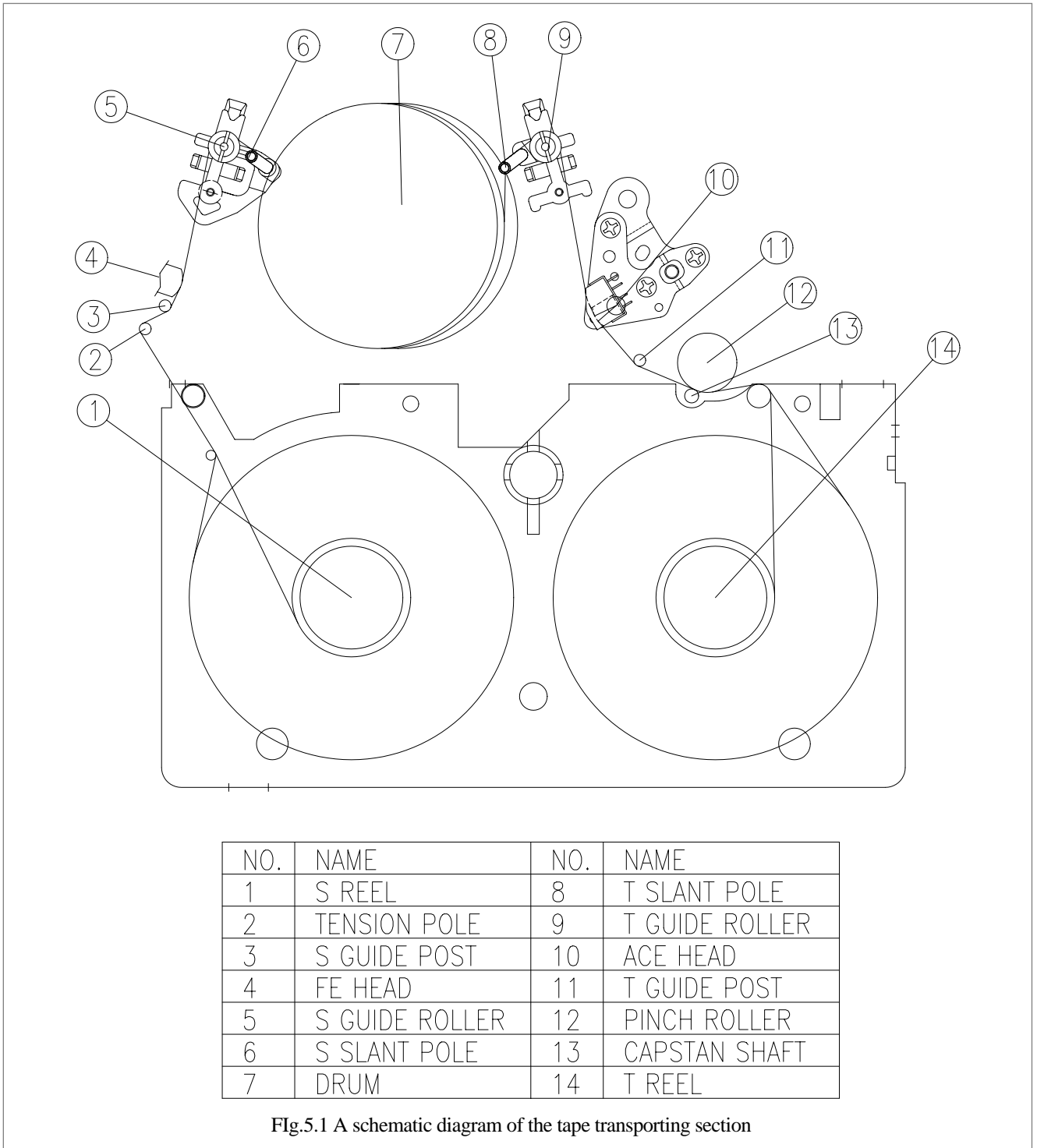

Fig. 4.6 Adjustment of the TENSION POLE

ADJUSTMENT OF THE TPAE TRANSPORTING SECTION.

Generally, tape transporting section has been precisely adjusted in the factory and does not require the ordinary readjustment. But there is the case that tape noise or impact on the deck mechanise, tape transporting section readjustment is required, in adjustment of the tape tranmission section consut the following flow chart.



If any components shown in Fig. 5.1, tape transporting section will be changed. To readjust the change of tape transporting section, keep in mind and follow the following check points.

ADJUSTMENT OF THE TPAE TRANSPORTING SYSTEM

Generally the TAPE TRANSPORTING SYSTEM has been precisely adjusted in the factory and does not ordinarily require readjustment. But when noise and tape damage take place and part assemblies that compose the TAPE TRANSPORTING SYSTEM are replaced, check and readjust the TAPE TRANSPORTING SYSTEM. Refer to the following FLOW CHART in order to adjust the TAPE TRANSPORTING SYSTEM.

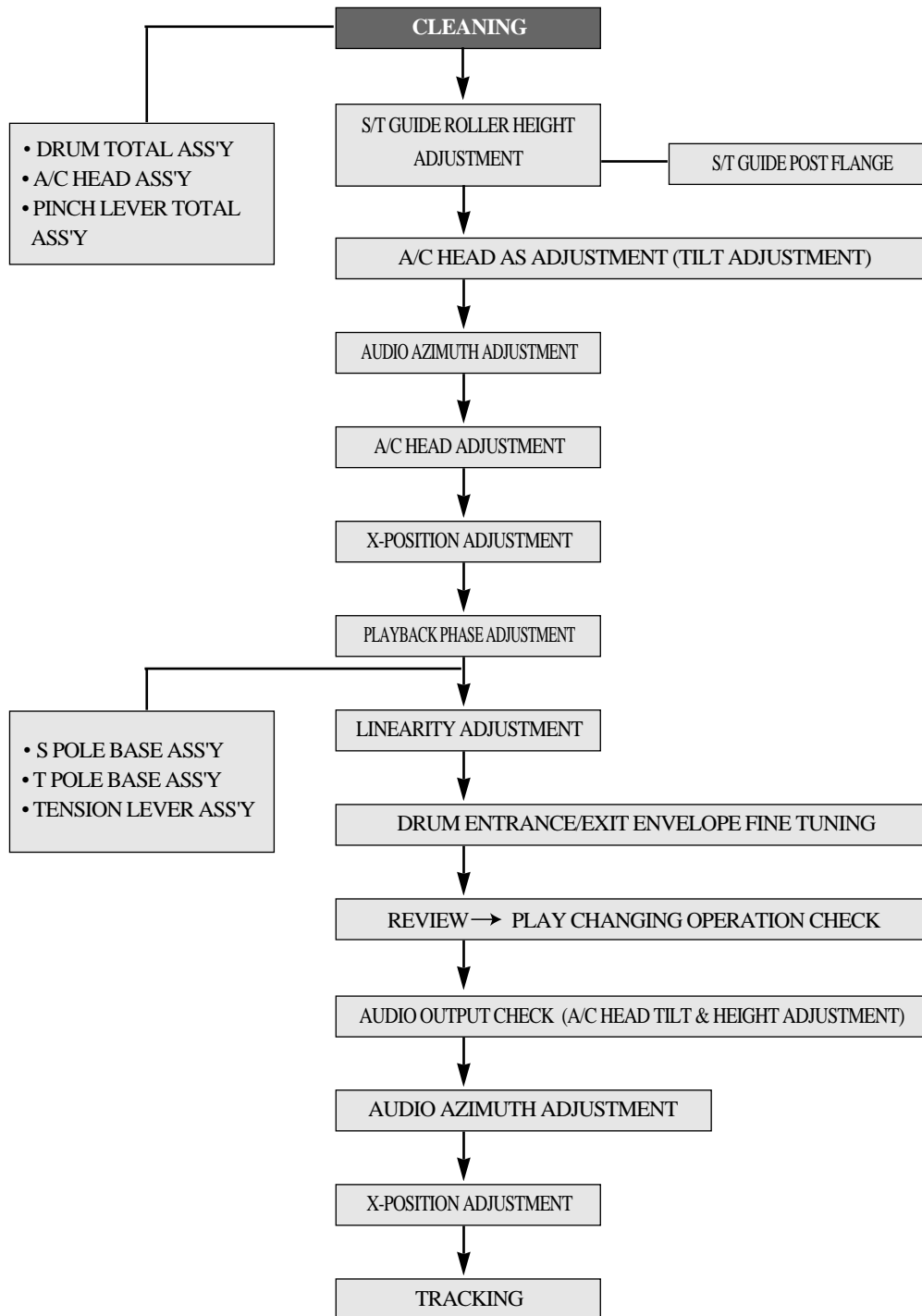

Table.1 ADJUSTMENT FLOW DIAGRAM OF THE TAPE TRANSPORTING SYSTEM

ADJUSTMENT OF THE TPAE TRANSPORTING SECTION. (CONTINUED)

A. Adjustment of the S/T GUIDE ROLLER

- Check the Playing back with a T-120 TAPE.
- Make sure that excessive tape wrinkle does not occur at each S.T GUIDE ROLLER.
- If tape wrinkle is observed at the S/T GUIDE ROLLER, turn the guide roller screw until there is not tape wrinkle.

B. Adjustment of the AC HEAD ASS'Y(TILT)

- Play back a T-120 TAPE and check the running status of lower side of GUIDE POST.
- If there is any problem, Turn the AC HEAD TILT SCREW until the running status improved (Fig. 5.2)

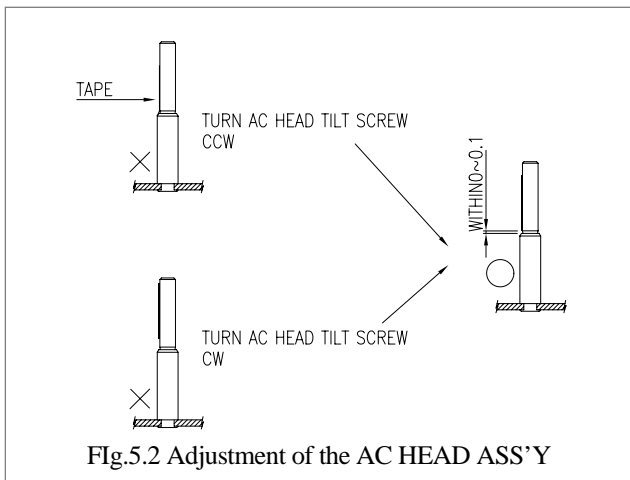

C. Adjustment of the AC HEAD Height(Fig. 5.3)

- Play back T-120 TAPE.
- Make sure that the gap between the lower end of AC head is 0.25m.
- If the measurement of the gap is different from the reference value 0.25m, turn the screw ①,③ until the desired gap is obtained.

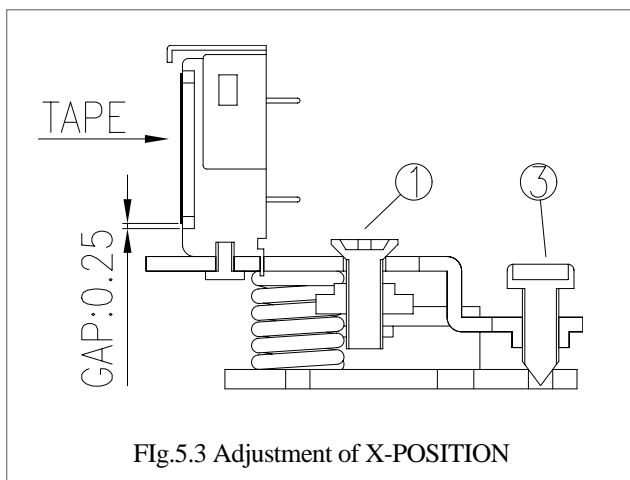

D. Adjustment of the AUDIO AZIMUTH(Fig. 5.4)

- Play back the ALIGNMENT TAPE (DN2 : SP, NTSC, 7KHz)
- Check the AUDIO output with a AUDIO LEVEL METER.
- Turn the AC HEAD AZIMUTH SCREW ② until the maximum AUDIO output(-9dBm ~ -3dBm) is obtained.

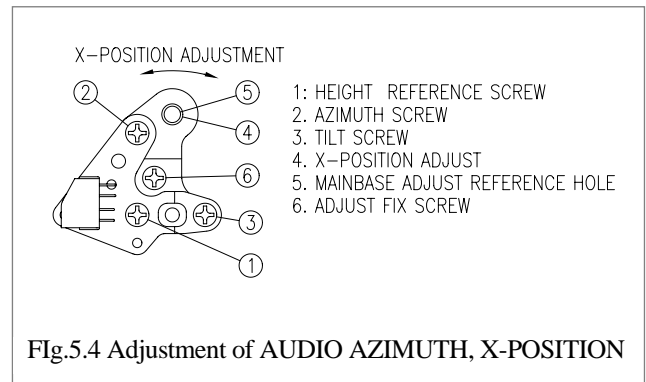

E. Adjustment of the X-POSITION(Fig. 5.4 5.5)

- Connect the PATH ADJ. FIXTURE to the PT01 on the MAIN CIRCUIT BOARD.
 - Play back the ALIGNMENT TAPE (DN2 : SP MONOSCOPE).
 - Connect the S/W pin and ENVE pin of the PATH ADJ. FIXTURE with the SCOPE PROBE.
 - Insert the adjustment bar in the AC HEAD ADJUST hole ④ and adjust the X-POSITION of the AC HEAD ASS'Y until the ENVE is maximum when the VR is on the CENTER.
- * Three is the possibility that another TRACKING CENTER can be occur when the AC HEAD ASS'Y turned completely in the counterclockwise direction, Hence adjust the X-position with AC HEAD ASS'Y adhering closely to the right side until the maximum ENVE is obtained.
- The adjustment of the X-POSITION finished, check if the AUDIO LEVEL is degraded, then readjustment of the AUDIO AZIMUTH is required.

Test Point	S/W PULSE TEST PIN	PATH ADJ. FIXTURE
	ENVELOPE TEST PIN	PATH ADJ.FIXTURE
Measurement Equipment	OSILLOSCOPE	
Adjustment	VR CONTROL	PATH ADJ.FIXTURE
	AC HEAD ADJUST HOLE	ADJUSTMENT BAR

ADJUSTMENT OF THE TPAE TRANSPORTING SECTION. (CONTINUED)

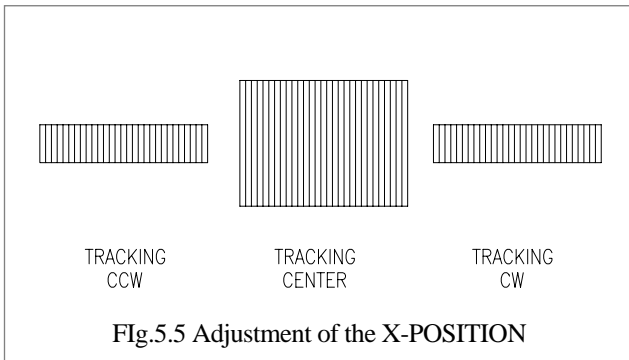

F. PLAYBACK PHASE ADJUSTMENT(Fig. 5.6)

Test Point	S/W PULSE TEST PIN	MAIN CIRCUTE BOARD
	ENVELOPE TEST PIN	MAIN CIRCUTE BOARD
Measurement Equipment	OSILLOSCOPE	
Adjustment	VR 595(PG SHIFTER)	MAIN CIRCUTE BOARD

PHASE GENERATOR(PG) SHIFTER determine the VIDEO HEAD SWITCHING POINT when the TAPE is played back.

If an adjustment of the PHASE GENERATOR(PG) SHIFTER is not done precisely, There can be a HEAD SWITCHING NOISE or a VERTICAL JITTER problem, vibration of the picture on the screen, not good quality of picture in special play back.

- Connect the PT01 on the MAIN CIRCUIT BOARD with a PATH ADJ. FIXTURE.
- Play back an ALIGNMENT TAPE (DN-2 : MON-SCOPE).
- Connect the S/W PULSE TEST PIN on the PATH ADJ.FIXTURE with a CHANNEL-1 SCOPE PROBE.
- Connect the VIDEO OUT on the MAIN CIRCUIT BOARD with a CHANNEL-2 SCOPE PROBE(1V/div).
- Control the PG VOLUME until the time interval between the SWITCHING PULSE and the V-SYNC SIGNAL is sithin the $6.5 \pm 0.5H$ as shown in fig. 5.6

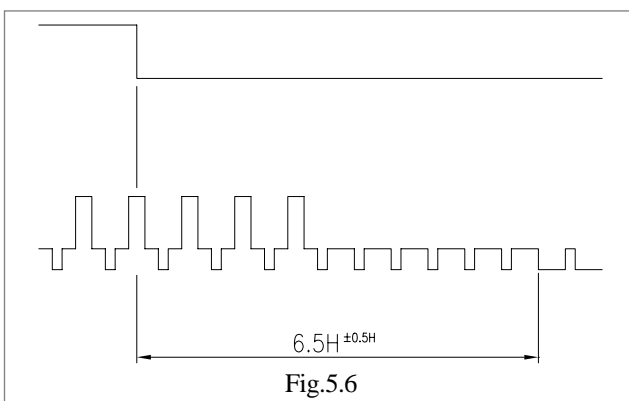

G.Adjustment of the LINEARITY(Fig. 5.7)

Test Point	S/W PULSE TEST PIN	PATH ADJ. FIXTURE
	ENVELOPE TEST PIN	PATH ADJ.FIXTURE
Measurement Equipment	OSILLOSCOPE	
Adjustment	VR CONTROL	PATH ADJ.FIXTURE
	S/T GHIDE ROLLER	TAPE TRANSMISSON SECTION

- Connect the PT01 on the MAIN CIRCUIT BOARD with a PATH ADJ.FIXTURE.
- Play back an ALIGNMENT TAPE (DN-2 : MONOSCOPE Signal).
- Connect the FIXTURE S/W PULSE TEST PIN on the PATH ADJ. CHANNEL-1 SCOPE PROBE.
- Connect the VIDEO OUT on the MAIN CIRCUIT BOARD with a CHANNEL-2 SCOPE PROBE.(1V/div).
- Adjust the VR CONTROL on the ADJ. FIXTURE until the ENVELOPE signal is maximum while play back the ALIGNMENET TAPE.
- Adjust the S/T GUIDE ROLLER until the envelope signal waveforms of the entrance and exit sides are as shown in Fig. 5-7.

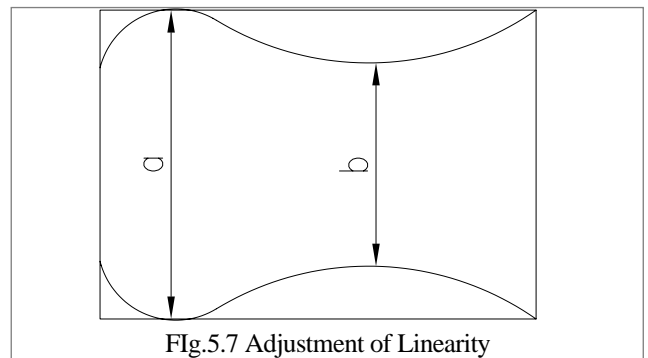

ADJUSTMENT OF THE TPAE TRANSPORTING SECTION. (CONTINUED)

H. Adjustment of the wave form of DRUM Entrance / Exit (Fig. 5.8)

Test Point	S/W PULSE TEST PIN	PATH ADJ. FIXTURE
	ENVELOPE TEST PIN	PATH ADJ.FIXTURE
Measurement Equipment	OSILLOSCOPE	
Adjustment	VR CONTROL	PATH ADJ.FIXTURE
	S/T GHIDE ROLLER	TAPE TRANSMISSION SECTION

- Connect the PT01 on the MAIN CIRCUIT BOARD with a PATH ADJ.FIXTURE.
- Play back an ALIGNMENT TAPE(DN-2 : MONO-SCOPE signal)
- Connect the S/W PULSE TEST PIN on the PATH ADJ. FIXTURE with a CHANNEL-1 SCOPE PROBE.
- Connect the VIDEO OUT on the MAIN CIRCUIT BOARD with a CHANNEL-2 SCOPE PROBE(1V/div).
- Turn the VR CONTROL on the PATH ADJ.FIXTURE clockwise or counterclockwise until the signal shape of ENVELOPE has the constant thickness.(Fig.5.8)
- Adjust the S/T GUIDE ROLLER if the thickness of the ENVELOPE signal is not uniform.

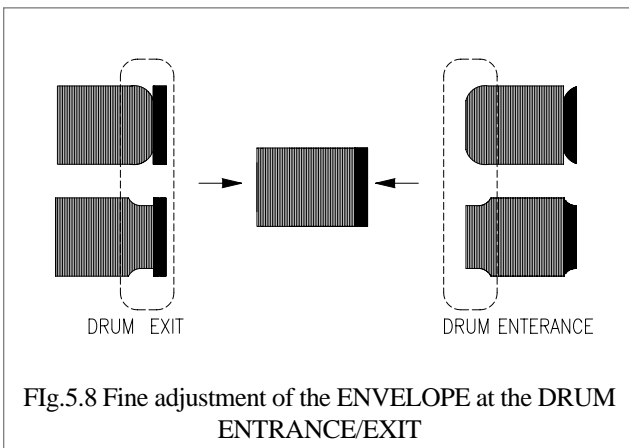

I. REVIEW ⇔ PLAY(Fig. 5.9)

Test Point	S/W PULSE TEST PIN	PATH ADJ. FIXTURE
	ENVELOPE TEST PIN	PATH ADJ.FIXTURE
Measurement Equipment	OSILLOSCOPE	
Adjustment	VR CONTROL	PATH ADJ.FIXTURE
	S/T GHIDE ROLLER	TAPE TRANSMISSION SECTION

- Connect the PT01 on the MAIN CIRCUIT BOARD with a PATH ADJ.FIXTURE.
- Play back an ALIGNMENT TAPE(DN-2 : MONO-SCOPE signal)
- Connect the S/W PULSE TEST PIN on the PATH ADJ.FIXTURE with a CHANNEL-1 SCOPE PROBE.
- Connect the VIDEO OUT on the MAIN CIRCUIT

BOARD with a CHANNEL-2 SCOPE PROBE(1V/div).

- Make the VR CONTROL on the PATH ADJ.FIXTURE to the center to maximize the ENVELOPE signal.
- Play back the REVIEW MODE about 15 second and alter the mode to PLAY MODE.
- Check whether the ENVELOPE waveform restore to its original form within 3 second when the REVIEW mode is changed to PLAY mode.
- If the requirement of “g” is not satisfied, Check the running status of tape on the lower part of T GUIDE POST and adjust the S/T GUIDE ROLLER precisely.

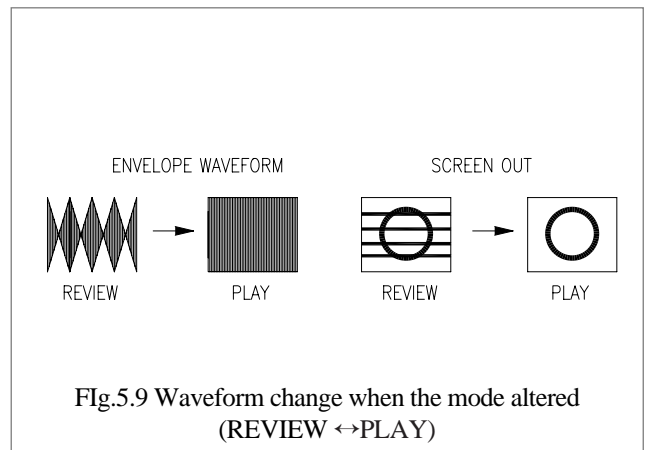

J. Checking for the J.AUDIO output waveform (Adjustment of AC HEAD TILT & Height)

Test Point	AUDIO OUTPUT	AUDIO OUTPUT JACK
Measurement Equipment	AUDIO LEVEL METER	

- Connect the AUDIO output jack with an AUDIO LEVEL METER.
- Playback an Alignment Tape (DN-1:Color Bar 1KHz Signal)
- Check if the AUDIO output signal level is over -9~-3dBm.
- If the requirement of “c” is not satisfied, readjust the AC HEAD TILT and the HEIGHT until the AUDIO output is maximized. (Fig. 5.2, 5.3)

ADJUSTMENT OF THE TPAE TRANSPORTING SECTION. (CONTINUED)

K. Adjustment of the AUDIO AZIMUTH

Test Point	AUDIO OUTPUT	AUDIO OUTPUT JACK
Measurement Equipment	AUDIO LEVEL METER	

- Connect the AUDIO output JACK with an AUDIO LEVEL METER.
- Play back the ALIGNMENT TAPE(DN-2:MONO-SCOPE 7KHz Signal).
- Check if the AUDIO output signal level is over : -9 ~ -3dBm.
- If the requirement of “c” is not satisfied, readjust the AZIMUTH SCREW of the AC HEAD until the AUDIO output is maxized.(Fig. 5.4)
- Repeat the Process of “**Adjustment of the wave form of DRUM Entrance/Exit**”

L. X-POSITION

Test Point	S/W PULSE TEST PIN	PATH ADJ. FIXTURE
	ENVELOPE TEST PIN	PATH ADJ.FIXTURE
Measurement Equipment	OSILLOSCOPE	
Adjustment	VR CONTROL	PATH ADJ.FIXTURE
	S/T GHIDE ROLLER	TAPE TRANSMISSION SECTION

- Connect the PT01 on the MAIN CIRCUIT BOARD with a PATH ADJ.FIXTURE.
- Play back an ALIGNMENT TAPE(DN-2: MONO-SCOPE Signal).
- Connect theS/W PULSE TEST PIN on the PATH ADJ.FIXTURE with a CHANNEL-1 SCOPE PROBE.
- Connect the VIDEO OUT on the MAIN CIRCUIT BOARD with a CHANNEL-2 SCOPE PROBE(1V/div)
- Check if the ENVELOPE is maximum when the VR CONTROL on the PATH ADJ. FIXTURE is in CENTER.
- If the requirement “e” is not satisfied, readjust the X-POSITION by referring to subitem “E”(Adjustment of the X-POSITION).
- Repeat the process of subite, “F(PLAYBACK PHASE ADJUSTMENT).

EXPLODED VIEW AND PARTS LIST

1. Exploded view of DECK Ass'y (Top View)

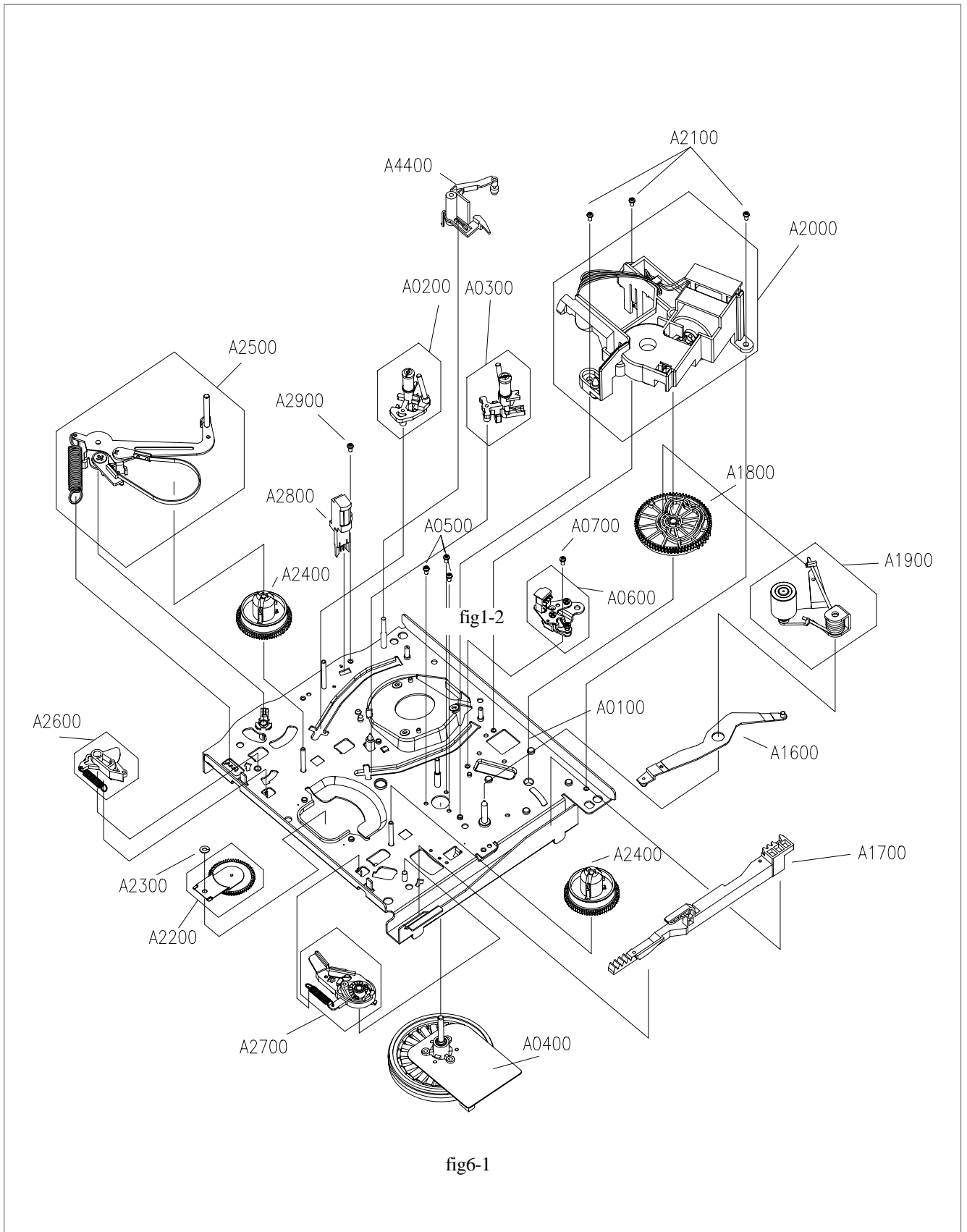

EXPLODED VIEW AND PARTS LIST (CONTINUED)

2. Exploded view of DECK Ass'y (Bottom View)

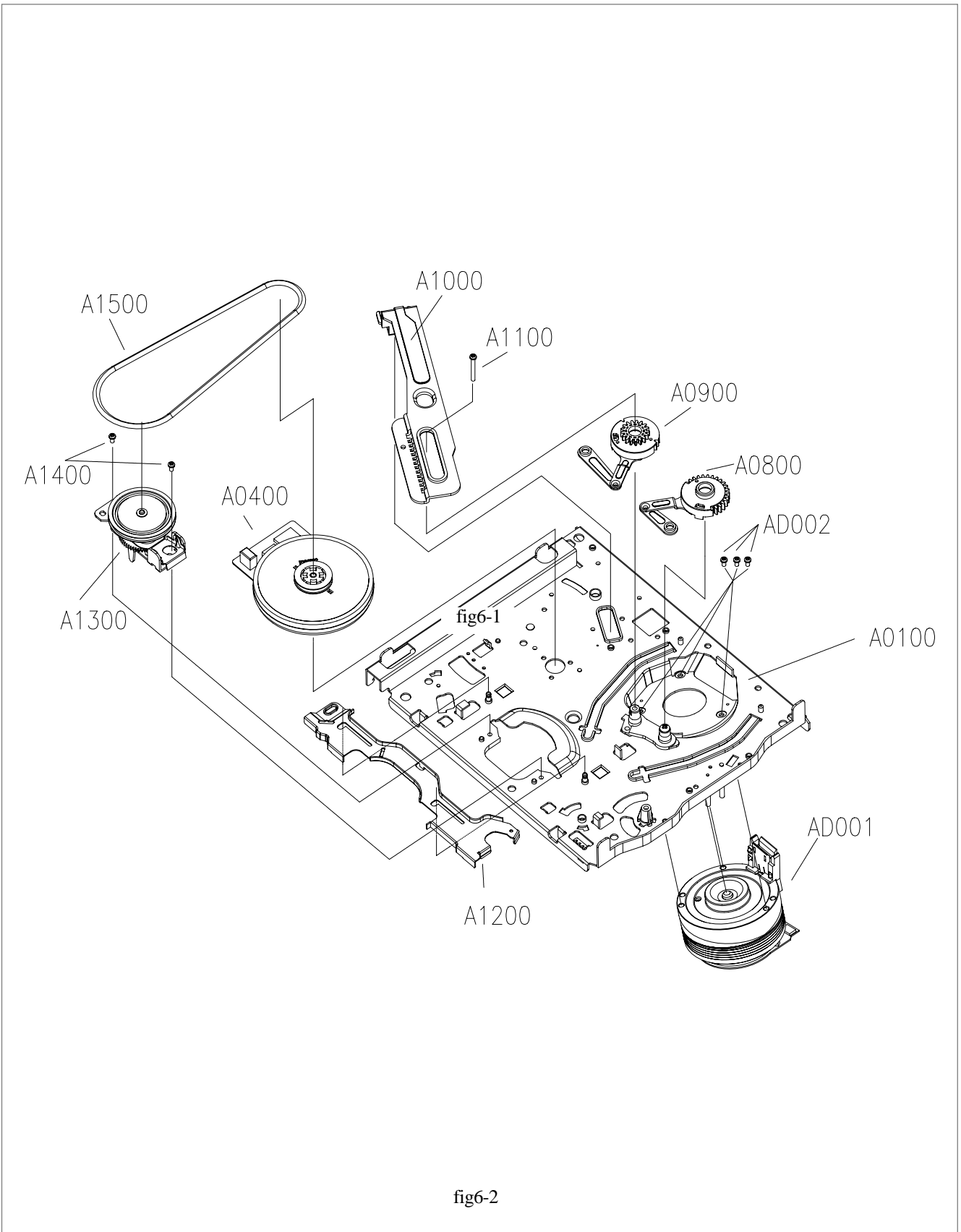

EXPLODED VIEW AND PARTS LIST (CONTINUED)

3. Exploded view of FL Ass'y

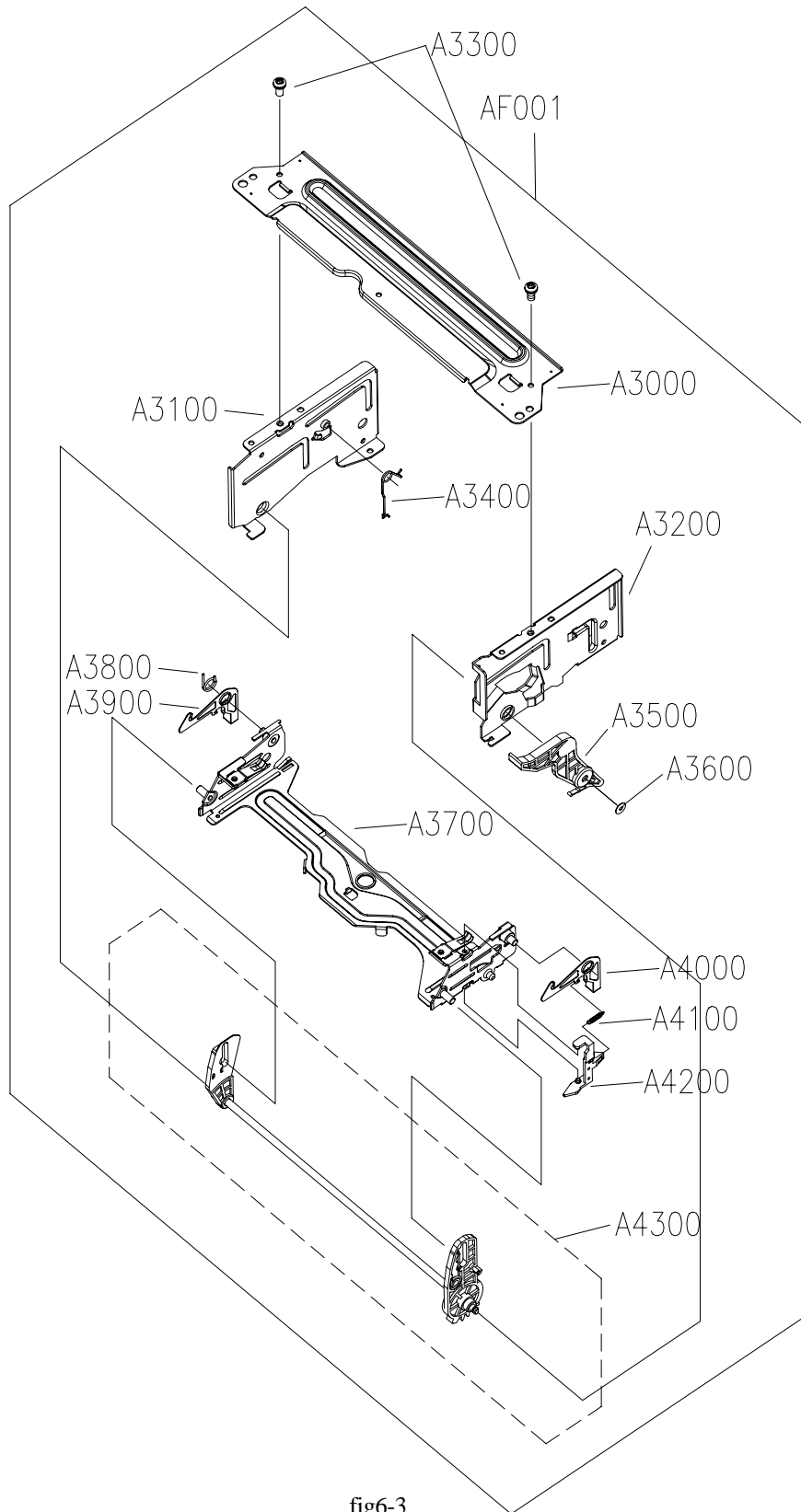

EXPLODED VIEW AND PARTS LIST (CONTINUED)

4. Exploded view Drum Total Ass'y

D0040

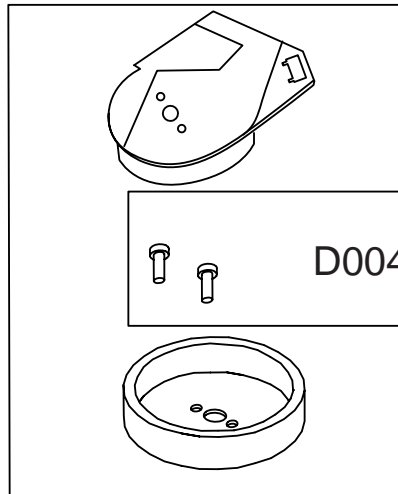

D0020

D0040

D0050



D0010

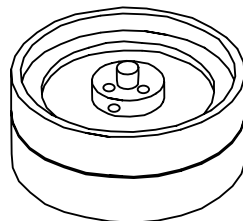

D0060

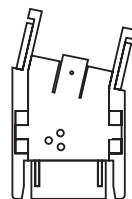

D0070

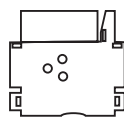

fig6-4

EXPLODED VIEW AND PARTS LIST (CONTINUED)

5. Parts List of Deck Total Ass'y (continud)

LOC	PART S/N	PART NAME	PART DISCRIPTION
NTSC			
M1000	97PC0273D-	DECK TOTAL AS	DRN-8329-CAR(2HD SP/EP HI-FI,DLC)
M1000	97PC0195D-	DECK TOTAL AS	DRN-8230(2HD SP/EP MONO,DLC)
M1000	97PC0194D-	DECK TOTAL AS	DRN-8430(4HD MONO, DLC)
M1000	97PC0128D-	DECK TOTAL AS	DRN-8630(4HD HI-FI, DLC)
M1000	97PC0301D-	DECK TOTAL AS	DRN-8200(2HD SP/EP MONO,NON)
M1000	97PC0328D-	DECK TOTAL AS	DRN-8201(2HD SP/EP MONO,NON,HEAD CLNER)
M1000	97PC0352D-	DECK TOTAL AS	DRN-8220(2HD SP/EP MONO,DLC)
M1000	97PC0300D-	DECK TOTAL AS	DRN-8400(4HD MONO, NON)
M1000	97PC0329D-	DECK TOTAL AS	DRN-8401(4HD MONO, NON,HEAD CLNER)
M1000	97PC0353D-	DECK TOTAL AS	DRN-8420(4HD MONO, DLC)
M1000	97PC0361D-	DECK TOTAL AS	DRN-8421(4HD MONO, DLC,HEAD CLNER)
M1000	97PC0299D-	DECK TOTAL AS	DRN-8600(4HD HI-FI,NON)
M1000	97PC0330D-	DECK TOTAL AS	DRN-8601(4HD HI-FI,NON, HEAD CLNER)
M1000	97PC0354D-	DECK TOTAL AS	DRN-8620(4HD HI-FI,DLC)
M1000	97PC0360D-	DECK TOTAL AS	DRN-8621(4HD HI-FI,DLC,HEAD CLNER)
M1000	97PC0365D-	DECK TOTAL AS	DRN-8230-H(2HD SP/EP, MONO,DLC)
M1000	97PC0364D-	DECK TOTAL AS	DRN-8430-H(4HD MONO,DLC)
M1000	97PC0359D-	DECK TOTAL AS	DRN-8630-H(4HD HI-FI,DLC)
PAL			
M1000	97PC0363D-	DECK TOTAL AS	DRP8421(4HD MONO,DLC,HEAD CLNER)
M1000	97PC0362D-	DECK TOTAL AS	DRP8621(4HD HI-FI,DLC,HEAD CLNER)
SECOM			

EXPLODED VIEW AND PARTS LIST (CONTINUED)

Parts List of Deck Total Ass'y (continud)

LOC	PART S/N	PART NAME	PART DISCIPTION
DRUM AS			
D0010		DRUM AS	REFERRING TO LIST OF DRUM PRICE ASS'Y
D0030	97SA324400	DRUM M/T AS	E20XL-25
D0030	97SA327100	DRUM M/T AS	DMVDMTO4M
D0040	7001260711	SCREW MACHINE	PAN 2.6X7 MFZN
D0050	97SA320400	EARTH GROUND AS	T-DRUM
D0060	97S2303600	HOLDER MAIN	POM(KEPITAL F20)
D0070	97S2303700	HOLDER CAP(A)	POM(2CH)
D0070	97S2303800	HOLDER CAP(B)	POM(4CH)
D0070	97S2303900	HOLDER CAP(C)	POM(6CH)
AD002	7051300611	SCREW MACHINE	PAN 3X6 SW MFZN
DECK AS			
AM001		DECK AS	REFERRING TOLIST OF DECK TOTAL ASS'Y
A0100	97SA318100	MAIN BASE AS	T-MECHA
A0200	97SA316500	S SLANT POLE AS	T-MECHA
A0300	97SA316600	T SLANT POLE AS	T-MECHA
A0400	97S8101600	MOTOR CAPSTAN	DMVCMC07DR
A0400	97S8101600	MOTOR CAPSTAN	NEW SANVIC
A0500	97S3102000	SCREW TAPPTITE	TT2 BIN-P 2.6X7 MFZN
A0600	97SA320500	AC HEAD AS	HVMXB1000AK
A0600	97SA326800	AC HEAD AS	HVMXA1101A
A0700	7051300611	SCREW MACHINE	PAN 3X6 SW MFZN
A0800	97SA316800	L LOADING AS	T-MECHA
A0900	97SA316900	R LOADING AS	T-MECHA
A1000	97S2709500	RACK LOADING	SECC T1.2
A1100	7008301911	SCREW MACHINE	WAS M3*19 MFZN
A1200	97S0904300	PLATE CONNECT	SECC T0.8
A1300	97SA319400	REEL BRKT TOTAL AS	T-MECHA
A1400	7274300611	SCREW TAPPTITE	TT3 RND 3X6 MFZN
A1500	97S5500400	BELT REEL	CR68
A1600	97S2623200	LEVER RELAY	SECC T1.2

EXPLODED VIEW AND PARTS LIST (CONTINUED)

Parts List of Deck Total Ass'y

LOC	PART S/N	PART NAME	PART DISCRPTION
DECK AS			
A1700	97S2709600	RACK FL	PBT(DY4410GF) NATURAL
A1800	97S2708200	GEAR CAM	DERLIN 100
A1900	97SA317100	PINCH LEVER TOT AS	T-MECHA
A2000	97SA318010	LC BRKT AS	T-MECHA
A2100	7274300611	SCREW TAPPTITE	TT3 RND 3X6 MFZN
A2200	97SA317300	IDLER PLATE TOT AS	T-MECHA
A2300	97S3108200	POLYWASHER	D2.6XD6.0XT0.5
A2400	97S2909400	TABLE REEL	POM(F20-03) BLACK
A2500	97SA317200	TENSIONLVR TOT AS	T-MECHA
A2600	97SA317400	S BRAKE AS	T-MECHA
A2700	97SA317500	T BRAKE AS	T-MECHA
A2800	97S8015000	HEAD FE	HVVFHU0030AK
A2800	97S8023100	HEAD FE	MH-131DT
A2900	7274300811	SCREW TAPPTITE	TT3 RND 3X8 MFZN
F/L AS			
AF001	97SA261010	F/LOADING AS	T-MECHA
AF002	7274300611	SCREW TAPPTITE	TT3 RND 3X6 MFZN
A3000	97S0903910	PLATE TOP	SECC T1.0
A3100	97S2401400	BRKT FL L	SECC T1.0
A3200	97S2401500	BRKT FL R	SECC T1.0
A3300	7274300611	SCREW TAPPTITE	TT3 RND 3X6 MFZN
A3400	97S3008800	SPRING FL LIFT	SWPB D0.8
A3500	97S2622700	LEVER DOOR OPENER	POM(F20-03) BLACK
A3600	97S3117300	WASHER POLY	D3.6XD8XT0.5
A3700	97SA415400	CST HOLDER SUB AS	T-MECHA
A3800	97S3008900	SPRING SAFETY LVR	SUS304 WPB D0.5
A3900	97S2621600	LEVER SAFETY L	SECC T1.0
A4000	97S2621700	LEVER SAFETY R	SECC T1.0
A4100	97S3009000	SPRING RELEASE LVR	SUS304 WPB D0.25
A4200	97S2621800	LEVER RELEASE	POM(F20-03) NATURAL
A4300	97SA317800	F/L LEVER AS	T-MECHA
AN002	2291131304	GREASE	DELUXE 5221G(NAM-YOUNG)
HEAD CLEANER AS			
A4400	97SA326900	HEAD CLEANER AS	T-MECHA

EXPLODED VIEW AND PARTS LIST (CONTINUED)

6. Parts List of Drum Price Ass'y

LOC	PART S/N	PART NAME	PART DISCRIPTION
NTSC			
AD001	97PA268901	DRUM PRICE AS	CYN-T210(2HD SP/EP NON)
AD001	97PA277471	DRUM PRICE AS	CYN-T212(2HD SP/EP DLC)
AD001	97PA264841	DRUM PRICE AS	CYN-T213(2HD SP/EP BLK)
AD001	97PA269001	DRUM PRICE AS	CYN-T410(4HD MONO NON)
AD001	97PA277571	DRUM PRICE AS	CYN-T412(4HD MONO DLC)
AD001	97PA264941	DRUM PRICE AS	CYN-T413(4HD MONO BLK)
AD001	97PA269101	DRUM PRICE AS	CYN-T610(4HD HI-FI NON)
AD001	97PA277671	DRUM PRICE AS	CYN-T612(4HD HI-FI DLC)
AD001	97PA265041	DRUM PRICE AS	CYN-T613(4HD HI-FI BLK)
AD001	97PA272071	DRUM PRICE AS	CYN-T312(4HD HI-FI NON)
PAL			
AD001	97PA265871	DRUM PRICE AS	CYP-KT112(2HD SP ONLY DLC)
AD001	97PA269901	DRUM PRICE AS	CYP-KT110(2HD SP ONLY NON)
AD001	97PA265971	DRUM PRICE AS	CYP-KT212(2HD SP/LP DLC)
AD001	97PA270001	DRUM PRICE AS	CYP-KT210(2HD SP/LP NON)
AD001	97PA266071	DRUM PRICE AS	CYP-KT412(4HD MONO DLC)
AD001	97PA270101	DRUM PRICE AS	CYP-KT410(4HD MONO NON)
AD001	97PA272771	DRUM PRICE AS	CYP-KT612(4HD HI-FI DLC)
AD001	97PA272601	DRUM PRICE AS	CYP-KT610(4HD HI-FI NON)
SECAM			
AD001	97PA266171	DRUM PRICE AS	CYS-KT412(4HD MONO DLC)
AD001	97PA270201	DRUM PRICE AS	CYS-KT410(4HD MONO NON)
AD001	97PA272971	DRUM PRICE AS	CYS-KT612(4HD HI-FI DLC)
AD001	97PA272801	DRUM PRICE AS	CYS-KT610(4HD HI-FI NON)

DAEWOO

DAEWOO ELECTRONICS CO., LTD

686, AHYEON-DONG MAPO-GU
SEOUL, KOREA

C.P.O. BOX 8003 SEOUL, KOREA

TELEX : DWELEC K28177-8

CABLE : "DAEWOOELEC"

E-mail : G7F00E@web.dwe.co.kr

TEL : 82-2-360-7802

FAX : 82-2-360-7877